

FP40

Flow and Energy Computer

OPERATING MANUAL

Manual revision: 260415 EN

Device version: 1.1

Before installing the device, you should carefully read the entire manual, in particular the points dedicated to the environment, health and safety.

The device has been manufactured in accordance with the requirements of European Union directives.

The instruction at all times should be stored in a safe place near the place of installation of the device.

Manufacturer's information

The manufacturer reserves the right to make changes to certain functions in connection with the continuous improvement of the design of the instrument.

MODBUS® is a registered trademark of Modbus Organization, Inc., North Grafton, MA 01536 USA

ILVA, Gilflo B, Gilflo SPOOL is a registered trademark of Spirax Sarco Ltd., Cheltenham GL51 9NQ, UK

TABLE OF CONTENTS

1	SAFETY INFORMATION.....	7
2	IDENTIFICATION, ACCESSORIES, STORAGE.....	10
2.1	Device name plate	10
2.2	Available versions	10
2.3	Equipment delivery	12
2.3.1	Standard content	12
2.3.2	Optional accessories	12
2.4	Storage	12
3	GENERAL PRODUCT OVERVIEW.....	13
3.1	Purpose	13
3.2	Main functions.....	14
3.2.1	Main applications A and B	14
3.2.2	Auxiliary application X, auxiliary channels	14
3.2.3	Process values inputs.....	14
3.2.4	Process values channels.....	16
3.2.5	Outputs.....	17
3.2.6	Data Archive	17
3.2.7	Communication with the master system (sharing results)	18
3.3	Supporting software	19
3.3.1	Device configuration program.....	19
3.3.2	Software for archive data visualization	19
4	FRONT PANEL AND GRAPHICAL USER INTERFACE (GUI).....	20
4.1	Front panel and function buttons.....	20
4.1.1	Title bar.....	21
4.1.2	Main Menu.....	22
4.2	Access control and passwords	23
4.2.1	Access control	23
4.2.2	Log-in and Log-out	24
4.2.3	Changing the password.....	24
4.2.4	Recover of lost password and getting service password	25
4.3	Language change	25
4.4	First run.....	26
4.5	Screens.....	26
4.5.1	Application A and B screens.....	26
4.5.2	Application X (auxiliary channels) screen	28
4.5.3	Single Result	28
4.5.4	User Tables	30
4.5.5	User Trends.....	31
4.5.6	Archive screen.....	33
4.5.7	Alarms status screen	34
4.5.8	Device Information screen	35
4.5.9	Settings screen.....	36
4.6	Print Screen	36
4.7	Write and read files via USB port	37
5	MEASUREMENTS APPLICATIONS	38
5.1	Medium Types	38
5.1.1	Water.....	38
5.1.2	Other liquids	38

5.1.3	Steam, superheated and saturated	38
5.1.4	Gas.....	39
5.2	Process values symbols	39
5.2.1	Application identifier	39
5.2.2	Channel symbols in application A and B	39
5.2.3	Channel symbols in application X.....	40
5.2.4	Symbols for totalizers and min / max values.....	40
5.3	Available types of main measuring applications	40
5.3.1	Liquid Flow	41
5.3.2	Liquid Heat	42
5.3.3	Liquid delta Heat (Closed loop)	43
5.3.4	Liquid delta Heat.....	44
5.3.5	Steam net Heat.....	45
5.3.6	Steam – Condensate delta Heat (Closed loop)	46
5.3.7	Steam – Condensate delta Heat.....	48
5.3.8	Steam generator.....	50
5.3.9	Gas Flow	52
5.3.10	Gas Heat	53
5.4	Summary of process values used in different types of applications	54
5.5	Hierarchy of process values calculations and failure indication.	56
5.6	Process engineering units.....	56
5.6.1	Process values	56
5.6.2	Totalizers	60
6	ARCHIVE.....	62
6.1	Archive file types.....	62
6.2	Creating new archive files.....	62
6.3	Start, resume, and stop archiving	63
6.4	View archive files on the device screen	63
6.5	Copy archive files from the device	64
6.6	Archive file organization.....	64
6.6.1	Data archive	64
6.6.2	Totalizers archive	65
6.6.3	Events archive	65
6.6.4	Settings Archive.....	66
6.6.5	Service Archive.....	67
7	WEB SERVER	68
7.1	Logging in to the web server	68
7.2	Downloading archive files	69
7.3	Viewing process values and totalizers	70
8	SUPPORTING SOFTWARE	71
8.1	FP40 Config.....	71
8.2	FP-Raport	72
9	MECHANICAL INSTALLATION	75
9.1	Panel mount version (FP40P).....	75
10	WIRING.....	76
10.1	Galvanic separation in the instrument.....	76
10.2	Power supply	77
10.3	FP40 Input Modules.....	78
10.3.1	IN6I(24V) – six channel 0-20mA or 4-20mA input type module	78
10.3.2	IN6T / IN3T – six/three channel temperature module	79

10.3.3	IN6 - six-channel universal analogue input module	80
10.3.4	IN6V – six channel voltage type input module	81
10.3.5	IN6D – six channel binary inputs module	82
10.3.6	IN3D – three-channel binary input module	83
10.3.7	2RS485(24V) – two RS485 port input module (Modbus RTU Master)	84
10.3.8	2RS485 – two RS485 port input module (Modbus RTU Master)	85
10.3.9	1HRT – HART (4-20 mA) port input module	86
10.3.10	OUT6RL – six channel relay outputs module	87
10.3.11	OUT3 – three channel analogue outputs module	87
10.3.12	PSBATT – back-up battery module	88
10.4	Wiring diagrams – power supply module M	90
10.5	Ethernet/LAN port	91
10.6	Shielding and grounding	91
11	SETTINGS AND DEVICE CONFIGURATION	92
11.1	Navigation in Settings menu	92
11.2	Change settings	95
11.3	Save settings	96
11.4	Order of configuration process (suggested)	97
11.5	General settings	97
11.5.1	General	97
11.5.2	Display	98
11.5.3	Date and Time	99
11.5.4	Service	99
11.6	Input and output settings	100
11.6.1	IN6I (24DC) / IN6I - Current Input Module 0/4-20 mA	100
11.6.2	IN6T / IN3T – Temperature Inputs Module	101
11.6.3	IN6 - Universal Inputs Module	101
11.6.4	IN6V - voltage input module 0-10 V	102
11.6.5	IN6D – Pulse Input Module	102
11.6.6	IN3D – Pulse Input Module	102
11.6.7	2RS485(24V) / 2RS485 - Modbus Master Input Module	103
11.6.8	1HRT - HART input module	104
11.6.9	OUT6RL - Relay Output Module	105
11.6.10	OUT3 - Analog Output Module	105
11.6.11	PSBATT - Emergency Power Supply Module	106
11.6.12	Module M (MAIN)	106
11.7	Communication settings	107
11.7.1	Ethernet	107
11.7.2	E-mail	108
11.7.3	Modbus TCP (Client)	110
11.7.4	RS485 (COM)	112
11.8	Main Application settings	113
11.8.1	Liquid Flow	113
11.8.2	Liquid Heat	114
11.8.3	Liquid delta Heat (Closed loop)	115
11.8.4	Liquid delta Heat	116
11.8.5	Steam net Heat	117
11.8.6	Steam – Condensate Δ Heat (Closed loop)	118
11.8.7	Steam – Condensate Δ Heat	119
11.8.8	Steam generator	120

11.8.9	Gas Flow	121
11.8.10	Gas Heat	122
11.8.11	Mass flow measurement.....	123
11.8.12	Volumetric flowmeters	123
11.8.13	Normalized volumetric flowmeters.....	123
11.8.14	Differential pressure flowmeters	123
11.9	Channels settings	127
11.9.1	Input data source.....	128
11.9.2	General.....	129
11.9.3	Totalizers.....	130
11.9.4	Alarms	131
11.10	Screen settings	132
11.10.1	User tables	132
11.10.2	User trends.....	133
11.11	Archive settings.....	134
11.12	USB screen, write and read settings file	135
11.13	Restore Factory settings	135
11.14	BTL service button.	135
12	EXTRA FEATURES.....	136
12.1	Computed channels	136
12.2	User characteristics	138
12.3	User Unit.....	139
12.4	User Medium	141
12.5	In-Line Variable Area (ILVA) flowmeter calibration table.....	141
13	MODBUS RTU / MODBUS TCP TRANSMISSION PROTOCOL	143
13.1	Basic information	143
13.1.1	Data types	143
13.2	Addresses of registers	143
14	TECHNICAL SPECIFICATIONS	146
15	ENTITY PLACING ON THE EU MARKET.....	153

1 SAFETY INFORMATION

Safe use of the product can only be guaranteed if it is properly installed, used and maintained by qualified personnel (more information in the following sections), in accordance with the instruction manual. In order to avoid risks, it is also necessary to comply with the general recommendations for safety tools and devices.

Symbols

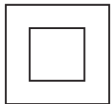

Equipment protected by double insulation or reinforcement of insulation.



The grounding clamp (ground) enables the correct operation of the product.
Do not use for electrical safety.



Attention, danger of electric shock.



Attention, risk of danger, see the accompanying documentation.



Attention, electrostatic discharge of sensitive circuits. Do not touch or operate the device without appropriate precautions against electrostatic discharge.



Important notes and information.

Warning

This product is designed and manufactured to withstand the forces encountered during normal use. Use of the product contrary to its intended purpose or incorrect installation of it, any type of modifications or repairs incompatible with the following instructions could:

- cause damage to the product or property,
- cause injury or death to personnel,
- void the warranty,
- invalidate the **CE** marking.



Disconnect the supply voltage before opening the product housing.

Warning

The product complies with the following directives and harmonized standards:

- Electromagnetic compatibility (2014/30/EC), meeting the following standards:
 - Immunity in industrial environments according to EN 61326-1:2013 (Table 2).
 - Class A conducted-radiated and radiated emissions according to EN 61326-1:2013.
- The product may be affected beyond the limits of EN 61326 if:
 - The product or its wiring is placed near the radio transmitter.
 - Excessive interference occurs in the supply voltage. Supply line (AC) protection should be installed if supply voltage disturbances are likely. Protection should combine filtering, attenuation, surge and pulse limiters.
 - Mobile phones and portable radios may cause interference when used within approximately 1 m of the product or its wiring. The actual necessary distance will vary depending on the installation and transmitter power.

Warning

This device is a Class A device. In a residential environment, it may cause radio interference. In such cases, its users may be required to take appropriate remedial measures.

Intend use

- Check that the product is suitable for your application.
- Determine the correct location of the installation.
- Before assembling Metronic AKP products, any environmental restrictions of the equipment specified in the instructions must be taken into account.

Access

Ensure safe access and if necessary a safe working platform (suitably guarded) before attempting to work on the product.

Lighting

Ensure that there is adequate lighting, particularly where detailed or complicated work is required.

Dangerous environment around the product

Consider areas at risk of explosion, lack of oxygen (e.g. tanks, excavations), hazardous gases, extreme temperatures, hot surfaces, fire hazard (e.g. during welding), excessive noise, machine movements.

System

Consider the effect on the complete system of the work proposed. Will any proposed action put any other part of the specific system or any personnel at risk?

Dangers might include isolation of vents or protective devices or the rendering ineffective of controls or alarms.

Tools & Consumables

Before starting work ensure that you have suitably required tools and/or consumables available at the work place.

Protective clothing

Consider whether you and/or others in the vicinity require any protective clothing to protect against the hazards of, for example, chemicals, high / low temperature, radiation, noise, falling objects, and dangers to eyes and face.

Work permits

All the work must be carried out or be supervised by a suitably competent person. Installation and operating personnel should be trained in the correct use of the product according to the Installation and Maintenance Instructions. Where a formal 'permit to work' system is in force it must be complied with. Where there is no such system, it is recommended that a responsible person should know what work is going on and, where it is necessary, arrange to have an assistant whose primary responsibility is safety. Post 'warning notices' if it is necessarily required.

Cleaning and maintenance

Metronic AKP products require no maintenance beyond periodic battery replacement. Expected battery life is 10 years after the expiry of which must be returned to the manufacturer for a replacement.

From time to time you should clean the casing with a dry, soft cloth. When cleaning, do not use solvents or abrasives. They may cause discoloration or scratch the surfaces of the device.

Disposal

The FP40 contains a battery. On disposal of the unit or component, appropriate precautions shall be taken in accordance with Local/National regulations.

Unless otherwise stated in the Installation and Maintenance Instructions, with the exception of the battery, this product is recyclable and no ecological hazard is anticipated with its disposal providing due care is taken.

Returning a product

Customers are reminded that under EHS regulations, when returning products to Metronic AKP they must provide information on any hazards and the precautions to be taken due to contamination residues or mechanical damage which may present an Environment, Health and Safety (EHS) risk. This information must be provided in writing including Health and Safety data sheets relating to any substances identified as hazardous or potentially hazardous.

2 IDENTIFICATION, ACCESSORIES, STORAGE

! Before shipment, each Metronic AKP device is checked and calibrated to ensure correct operation. At the time of receipt, the contents of the package should be checked for possible damage to the shipment or lack of order items.

2.1 Device name plate

The nameplate in the form of a sticker is located in the upper or side part of the device housing. For unambiguous identification of the device, compare the data plate with the figure below.

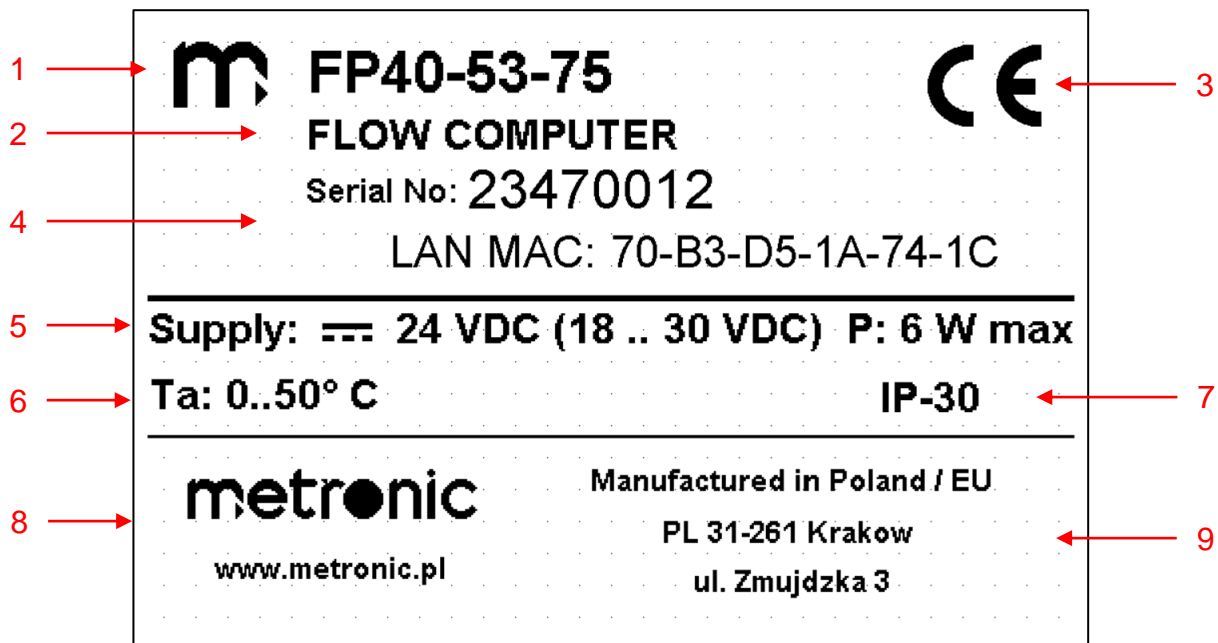

Description of the markings:

1. Manufacturer's logo
2. Name and type of device
3. CE marking
4. Serial number and MAC address
5. Supply voltage and maximum power consumption
6. Ambient temperature
7. Degree of protection
8. Name and website of the manufacturer
9. Place of manufacture of the instrument

2.2 Available versions

The flow computer can be equipped with an optional analogue output / outputs 4-20 mA. Offered versions of the device:

FP40	Slot A	Slot B	
	-XX	-XX	Module code from the table below

For example:

FP40 with HART module and six current inputs (4-20mA) has a code: FP40-75-11
 FP40 with six inputs (4-20mA) has a code: FP40-11-0

0	--	no module is installed in the slot
11	IN6I(24V)	six analogue inputs with standard current loop output 0-20mA or 4-20mA powered from internal 24 VDC
12	IN6I	six analogue inputs with standard current loop output 0-20mA or 4-20mA (or passive transmitters with external power supply)
23	IN6T	six analogue inputs for connection temperature RTD sensors type Pt100, Pt200, Pt500, Pt1000, Ni100, Ni120, Ni1000, Cu50, Cu53, Cu100, KTY81, KTY83, KTY84 and connection thermocouples TC type J, L, K, U, E, N, B, R and S; and linear measurement of resistance 0 ... 4500 Ω or voltage -140 ... +140 mV
41	IN6V	six analogue inputs for connecting as standard -10 .. +10 V, 0..10 V, 2 .. 10 V, 0 .. 5 V, 1 .. 5 V
53	IN6	six analog inputs, inputs 1-3 enable connection of RTD temperature sensors, TC thermocouples and linear measurement of resistance 0 .. 4000 Ω or -140 .. +140 mV, inputs 4-6 enable the connection of transducers in the 0 / 4-20mA standard, 0 / 2-10V, 0 / 1-5V
55	IN4SG	four analog inputs +/-30 mV for direct connection of strain gauges with a sensitivity of 1, 2, 4 mV / V or other, four discrete inputs for resetting (tare) analog inputs, power supply for strain gauges 5 VDC
61	IN6D	six binary inputs for status tracking, frequency measurement
62	IN3D	three binary inputs for status tracking, frequency measurement (0.1 .. 12 500 Hz), pulse counting (0 .. 100 Hz) with the possibility of powering transducers
71	2RS485(24V)	two independent and galvanically separated RS-485 ports for reading transducers or other devices operating in the Modbus RTU standard; extra 24VDC voltage source power supply for external transducers
72	2RS485	two independent and galvanically separated RS-485 ports for reading transducers or other devices operating in the Modbus RTU standard
75	1HRT	one HART (4-20 mA) port with the possibility of powering transmitters, operating in the Primary Master mode or in the Secondary Master mode
81	OUT6RL	six solid state relays output rated at 24 VAC / 0.5 A or
91	OUT3	three programmable analogue outputs 0/4-20mA, 0/1-5V, 0/2-10V
95	PSBATT	supplying the device with NiMH storage batteries in the event of voltage break (backup) or periodic operation with battery power supply (from 1 to 20 hours depending on the configuration)

2.3 Equipment delivery

It is necessary to carefully compare the actual state of the contents of the package with the list of elements listed in the following subsections. In the event of damage or missing elements, an appropriate protocol should be drawn up in the presence of the carrier, which should bear the date of receipt and the signature of the delivery of the parcel.

2.3.1 Standard content

- Device FP40
- Warranty card
- Calibration certificate

2.3.2 Optional accessories

- Convertor CONV485E
- Convertor CONV485USB-I
- Convertor CONVUSB
- Power supply
- Flash Memory Drive (Memory stick)
- Calibration report

2.4 Storage

If the device is to be stored for a certain period of time before the start of assembly, the conditions for proper storage must be observed. The device should be stored at temperatures in the range of -30°C to 70°C and with relative humidity maintained between 5% and 95% (without condensation).

Before installing and connecting the power supply, make sure that there is no condensation inside the device.

3 GENERAL PRODUCT OVERVIEW

3.1 Purpose

The FP40 is a universal flow computer with electronic data recording. The flow computer purpose is to measure:

- flow and thermal energy of steam and water according to IAPWS-IF97 in the operating range:
 - 52 °C to 800 °C and 0.02 MPa|a to 16.5 MPa|a for superheated steam,
 - 0 °C to 372 °C for saturated steam (with temperature measured),
 - 0.02 MPa|a to 16.5 MPa|a for saturated steam (with pressure measured),
 - 0 °C to 350 and 0.02 MPa|a to 20.0 MPa|a for water.
- flow and heat energy of liquids other than water according to the characteristics of the medium entered by the user,
- flow of technical gases according to the perfect gas equation or according to the characteristics of the medium entered by the user,
- flow and thermal energy of technical gases according to the characteristics of the medium entered by the user.

The computer may be configured to monitor one or two independent advanced measuring flow applications (pipelines) with data retention of 0.5 s. All data is measured, calculated and updated during this period.

The flow computer can support different types of flow meters:

- differential pressure flowmeter device according to an iterative algorithm in accordance to EN ISO 5167 (with some limits to other liquids and gases other than water or steam)
- small bore precision orifice in accordance to ASME MFC-14M-2003 (with some limits to other liquids and gases other than water and steam)
- differential pressure flowmeter device according or square root approximated characteristics
- differential pressure flowmeter device ILVA, Gilflo B, Gilflo SPOOL manufactured by Spirax Sarco Ltd., UK (only for steam and water and only based on manufacturer calibration table)
- mass
- volumetric

The device is designed for industrial applications in independent measuring systems or as a part of computer measurement and control systems. The device can be connected via the built-in Ethernet or RS485 communication ports.

The 4 inch colour display with touchscreen provides easy user interface and clear measured data presentation. The number of advanced functions, data presentation, and data acquisition make the device convenient as an electronic recorder and data analyser of technological processes and emergency states in plant. There are seven language available for the device interface:

- English
- German
- Spanish
- French
- Italian
- Polish
- Portuguese.

3.2 Main functions

3.2.1 Main applications A and B

The device can be set up for two independent measuring applications: A and B. Each may be configured to one of available advanced flow and/or energy measurements:

- Liquid flow
- Liquid heat
- Liquid delta heat
- Steam net heat
- Steam and condensate delta heat
- Steam generator
- Gas flow
- Gas heat

3.2.2 Auxiliary application X, auxiliary channels

Auxiliary X application may use up to 16 free programmable channels. Channels in the application X can be used to measure other auxiliary process values or to copy channels values from system A and B in order to do some other calculations (e.g. sum of energy from A and B) as a math channels. In application X it is not possible to select the predefined flow and energy application.

3.2.3 Process values inputs

There are few available ways to input process value to the flow computer:

- as a binary signal (pulse or frequency),
- as an analogue signal (RTD or 0/4-20 mA),
- as a digital value read via Ethernet port (Modbus TCP protocol),
- as a computed value (user math formula based on other process channels values).

The input have to be assigned to a proper channel in the configured application. If required one input may be assigned to more channels, also in different applications. (E.g. the same temperature measured by RTD sensor may be used in the applications A and B)

3.2.3.1 RTD resistive inputs – IN6T or IN6 card (3 inputs)

IN6T - has 6 inputs and IN6 has 3 resistive inputs. Many RTD characteristics are available: Pt100, Pt200, Pt500, Pt1000, Ni100, Ni120, Ni1000, Cu50, Cu53, and Cu100. It is also possible for the user to enter their own characteristics. Each input can be operated in a 2, 3 or 4-wire arrangement.

3.2.3.2 I type (0/4-20 mA) – IN6I (24DC), card IN6 (3 inputs)

IN6I (24DC) - has 6 current inputs, IN6 - has 3 current inputs. Each can accept signals 4 to 20 mA or 0 to 20 mA from passive or active current loop transmitter. Passive transmitters may be supplied directly from the flow computer.

3.2.3.3 F type binary – modules IN3D, IN6D

IN3D - three frequency inputs, inputs can work in different modes.

- Frequency – frequency measurement in range from 0.02 Hz to 12.5 kHz.
- (E.g. used for Vortex flowmeter with frequency output.)
- Pulse counting – low frequency input, when number of pulses is more important than frequency. (E.g. water rotary flowmeter with contact output.)

- State – on/off tracking with process value assigning for each state. (E.g. used for valve open state without flowmeter installed or flow direction indication.)

F type input can accept typical industrial standard signals, depending on chosen input signal type:

- OC – for transmitters with passive transistor OC output or contact output
- Voltage – for active voltage signal
- NAMUR – (simplified) for transmitters with so called NAMUR output
- E+H – for transmitters with current loop type output

Each input has independently selectable in configuration menu low pass filter for signals below 300 Hz.

3.2.3.4 IN6D - Six pulse inputs, inputs can be used in different settings.

- dedicated to measure frequency, pulse counting or state tracking,
- frequency range of 0.1 ... 1000 Hz (pulse counting in range 0 ... 100 Hz),
- 0 ... 4 VDC / 5.5 ... 34 VDC (3.6 mA) according to EN61131-2 characteristics,
- other switching current level at 0.3mA, 0,9mA, 3,0mA or 3,6mA can be selected with jumpers located on the module PCB,
- accepts passive pulse transmitter (contact or transistor configuration OC), the source voltage or current pulses,
- galvanic separation from the remaining device circuits, no separation among the input channels,
- each input has a separate three-pole plug-in terminal block,
- each input has a LED to indicate the input state level,
- two color LED informing about the module's operating status.

3.2.3.5 Digital inputs via Modbus RTU protocol – card 2RS485

2RS485 (24V) - has two independent and galvanic separated RS485 ports. The module allows you to read up to 25 digital sizes in 32 or 64 bit fixed or floating-point format.

3.2.3.6 Digital inputs via HART– card 1HRT

1HRT - 4-20mA current loop with an internal 24VDC power source allowing you to connect up to 15 devices in multidrop mode. Working as a Primary Master or Secondary Master.

3.2.3.7 Digital inputs via Modbus TCP protocol

The device allows remote reading of up to 40 values from 20 devices using Modbus TCP protocol. Detailed information in chapter [Modbus TCP \(Client\)](#).

3.2.3.8 Constant value inputs

In special situations, it may be necessary to enter a constant value as an input process value. As a consequence this constant value is used as an input value for all calculations in flow computer.

3.2.3.9 Computed inputs based on other channels values

The input process value may be defined as a result of other process or even as a result of math formula based on other process results. (E.g. mass flowrate in application B required as an input value may be taken from application A, where it was calculated as a result of compensated mass flow measurement.)

3.2.4 Process values channels

3.2.4.1 Channels organization

All process values, measured and calculated are ordered into channels. In main applications A and B the number and types of channels are determined based on chosen application type. The symbols are also determined. The auxiliary process values in application X are defined and named by the user.

Some process values, mainly input values have to be assigned to inputs, scaled and configured (e.g. pressure measured as a 4-20mA input signal). Other channels are result of internal calculation (e.g. steam power is result of calculation from flowrate, temperature and steam tables.)

More information is in chapter [Channel types, process quantities](#) and in chapter [Types of measuring channels A and B](#).

3.2.4.2 Process units

For each channel it is possible or even required to select an engineering unit. The entered unit affects the other results in calculations process of flow computer. Units have been defined in the device (list of available units is in the chapter [Process result units](#)).

Due to the possibility of implementing various, also unusual measurement systems, for some channels it is possible to define user unit. Details are in the chapter [User Units](#).

3.2.4.3 Computed channels, math formulas

Some channels may be defined as Computed. Selected mathematical operations are available within the calculation channels: addition, subtraction, division, multiplication, raising to 2, 3 or any power and root. The math formula is entered by user as a string, and may contain up to 200 characters. Also values from other channels and totalizer values can be used in formulas. More information, see the [Computed Channels](#) chapter.

3.2.4.4 Totalizers

For flowrate type channel can be configured up to two independent totalizers. Every totalizer can be configured to non-resettable or resettable mode. Totalizer reset may be executed by the user on the touchscreen or set to be reset automatically daily, weekly or monthly (more information in the section [Totalizers](#)).

If required, the number of totalizers can be multiplied by creating the copy of the channel in system X using math functions.

For channels assigned to F-type input and configured to the "Pulse counting" mode, totalizing is determined on precisely summing the input pulses multiplied by the factor (weight) of a single pulse. In this mode the flowrate value is only indicative.

Selected totalizer values may also be periodically sent as an e-mail message up to five different addresses at the indicated time every day, on the selected day of the week or on the selected day of the month.

3.2.4.5 Alarm notifications and control

Each channel can have two independent alarm thresholds. Each threshold can be defined as Low or High. There are two modes available for alarms:

- Alarm (latched, requiring confirmation)
- Control (non-latched, not requiring confirmation).

More details are described in the chapter [Alarm acknowledgement \(Alarm/Control mode\)](#).

Exceeding alarm thresholds is indicated by the alarm icon and can be signalled by beeper activation ([Alarm signalling on the device](#)). Also assigned process value may change the colour to attract user attention.

Alarm information can be assigned to one of four output relays.

The device may also send an e-mail message at the beginning and end of the alarm alert. The message may be sent up to five different addresses.

3.2.5 Outputs

3.2.5.1 Relays (RL1 to RL4)

The device has 4 solid state relay outputs. The outputs can be active when the alarm thresholds are exceeded, which makes it possible to configure a simple control system. It is possible to assign the same relay output to several alarm thresholds. There are three modes available for relay outputs:

- Normally open – output closed when active,
- Normally closed – output opened when active,
- Pulsation – 1 Hz pulses are generated when active.

In the event of a power failure or e.g. restarting the device, the relay outputs remain in the open state (regardless of configuration).

FP40 can be equipped with an additional card of 6 relay outputs – **OUT6RL**

3.2.5.2 Analogue 4-20mA outputs

Device has one current output. The output have to be assigned to one of process value channels to retransmit its value in configured range. The output can indicate a failure with a user-defined current value (e.g. 3.6 mA). The current loop of the output have to be powered from an external power source.

Optionally, the FP40 can be equipped with a card of 3 active analogue outputs – **OUT3**

3.2.6 Data Archive

Process values and service information are saved using an advanced archiving system. The device has an internal 2 GB non-volatile memory.

Data is saved in form of three files types: process data archive, totalizers archive, events archive.

Depending on the level of access, it is possible to display the event log saved in the service archive. The archive is displayed in the form of a table. The log contains all events and authorized actions performed since the first start of the device. Access to the register from the device screen allows the supervising staff to verify the changes made in device settings.

The data is saved as .csv format text files with encrypted checksum to provide secure data control.

The archive files may be copied via build-in USB port or device www server via Ethernet port.

Detailed information may be found in the [ARCHIVE](#) chapter.

3.2.6.1 LCD display and data presentation

User interface is based on color graphic LCD with resistive touch panel. The FP40 has a 4" display with a resolution of 800x480 px. User interface is organized into screens groups for intuitive navigation and data presentation.

For more information see the chapter [Front Panel and Graphical User Interface](#).

3.2.6.2 Screens for A and B applications

Main process data is available for in screens separately for application A and B. Data is presented as a synoptic graphical pictures. Touchscreen allows to switch over to detailed screens with data table detailed channel information with trend, maximum and minimum values, totalizers.

3.2.6.3 Screens for auxiliary X application

Data is presented as a 16 values table. Similarly as for A and B the touchscreen allows to switch over to detailed screens with data table detailed channel information with trend, maximum and minimum values, totalizers.

3.2.6.4 User tables and Trends

User may configure own Tables and Trends based on available process values from all three applications A, B and X. Up to six tables with maximum sixteen values may be configured for each table. Table may contain also totalizers, maximum and minimum values. Each table may contain mix of process values from application A, B, X ordered in user convenient way. By analogy, there are available up to six screens with process values trends. Each screen may contain up to six channel values, mixed from all three applications.

3.2.6.5 Screens for Archive, Alarms and Info

Separate screens are available for information and control of archived data, alarms and general information on device. In Archive screen it is possible to view archived data in graphical form.

3.2.6.6 Service screens for Settings and I/O status

All settings may be configured using advanced settings interface. For current I/O status and quick view over hardware operation information on screen Info is available.

3.2.7 Communication with the master system (sharing results)

The instrument may be integrated into the plant supervising data system. There are two protocols available for process data sharing:

- MODBUS RTU over built-in RS485 serial port
- MODBUS TCP over built-in 100 tBase Ethernet port

The map of registry addresses and details of data formats are described in the chapter [MODBUS RTU / MODBUS TCP TRANSMISSION PROTOCOL](#).

In addition user may have access for process data and archive files via build-in web server.

3.3 Supporting software

Additional software for the device can be downloaded from the manufacturer's website: www.metronic.pl.

3.3.1 Device configuration program

Dedicated FP40 Config program allows user to configure the FP40 device using a standard PC. For safety reason settings are at first generated as a file. In next step new settings are uploaded to the device via USB port and standard memory flash drive. It is also possible to download settings from the device to the PC in the same way.

The program is characterized by intuitive operation and interface similar to the device interface. The program can be installed on computers with MS Win operating system.

For details see [FP40 Config](#).

3.3.2 Software for archive data visualization

The FP-Report program is used for simple analysis and visualization of measurement results using a PC. The unregistered version of the program works for 10 minutes with full functionality. For full functionality without time restriction user must register program. The program can be installed on computers with the Microsoft Windows operating system.

4 FRONT PANEL AND GRAPHICAL USER INTERFACE (GUI)

4.1 Front panel and function buttons

The front panel of the device has a built-in touch panel, color 4" LCD display, which is the main tool for communication with the user.

The display is divided into two areas:

1. Title bar with function icons; touching the icons allows to switch between screens and display a drop-down menu
2. Main screen for displaying all process data and screens, entering data using the on-screen keyboard

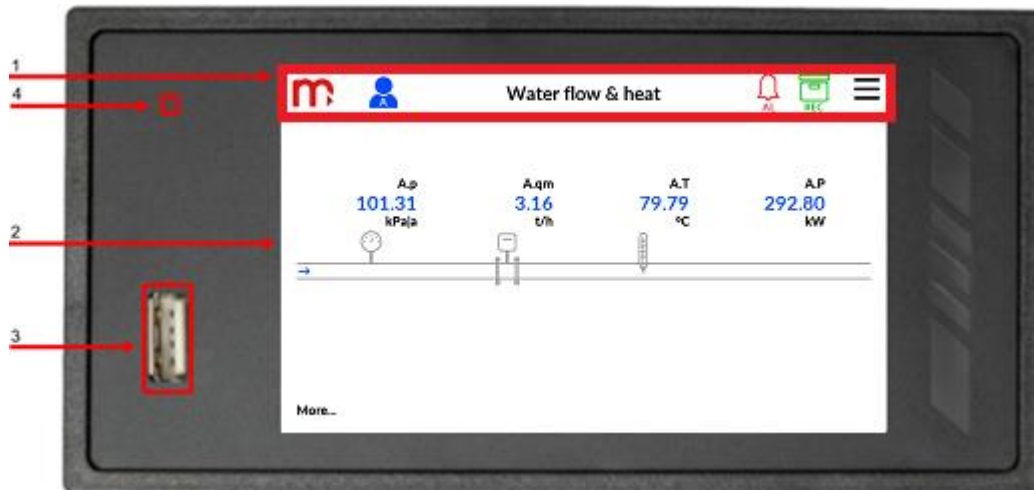

In addition, on the front panel of the device there is also:

3. USB port - for connecting an external USB memory device (flash type) to transfer data stored in the internal memory of the device to a computer or to load user files (e.g. settings file, user media file)
4. LED indicator indicates extra device status information:
 - Blue - lights up when starting the device, when the display is dimmed to 0%, when taking a screenshot, when reading / writing files (pulses when copying data between the internal memory and the external USB memory)
 - Green - lights up / pulsates when creating a new file in internal memory (e.g. when creating a new archive file), lights up when the device is in bootloader mode (mode to change the firmware of the device)
 - Red - error information



Do not use sharp or metal objects to operate the touch screen. Improper operation may damage the display.

4.1.1 Title bar

The title bar is located at the top of the screen and is always seen in the display with very few exceptions.

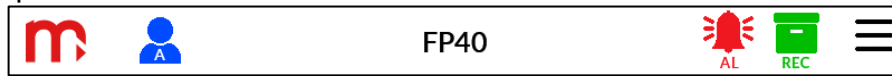

Information about the login status: active icon, tapping opens the Login Window (more information in the chapter [Access control, login and changing the user's password](#)).

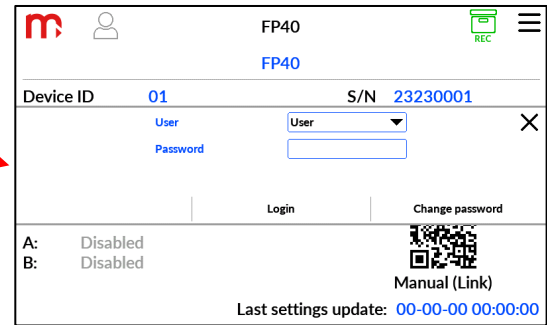
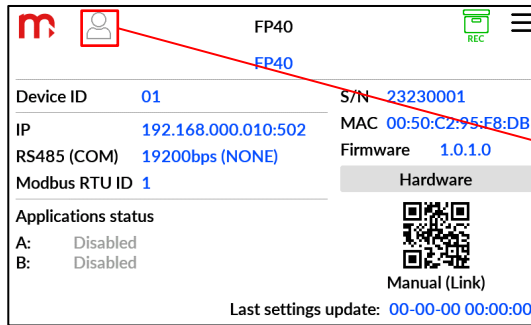

FP40 Title of the currently open window (for more information, see [User screens](#)).



Information about the failure of the measurement or remote input (status of the measurement inputs available in the [Service Test Screen \(IO TEST\)](#)).



Alarm status; A flashing icon indicates an unconfirmed alarm; a filled icon indicates that at least one alarm is active and all alarms are acknowledged; An empty icon indicates that at least one alarm is configured, but none are inactive; The absence of an icon indicates that not a single alarm is configured; Active icon, tapping opens the Alarm Screen (for more information, see [Alarm Screen](#)).

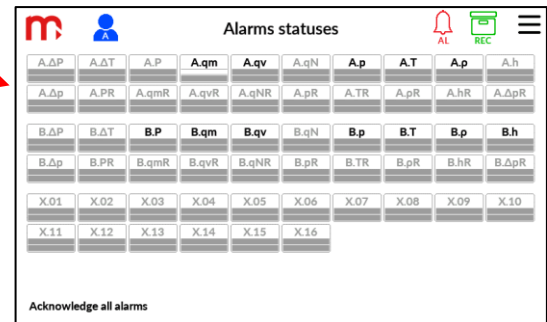
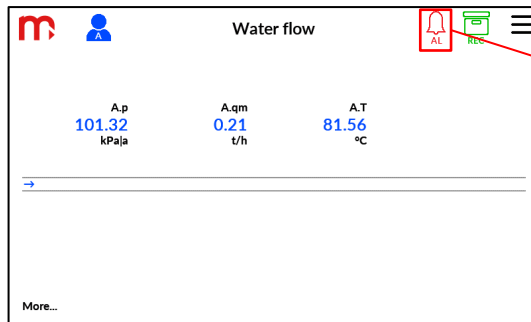

4.1.2 Main Menu

☰ Main Menu icon, tapping opens or closes its contents.

Swiping up or down allows to see all available buttons.

The drop-down menu contains a list of buttons with a current date and time indicator at the top. Buttons are used to switch over to other screens. The content of the drop-down menu depends on the enabled functions and device configuration.

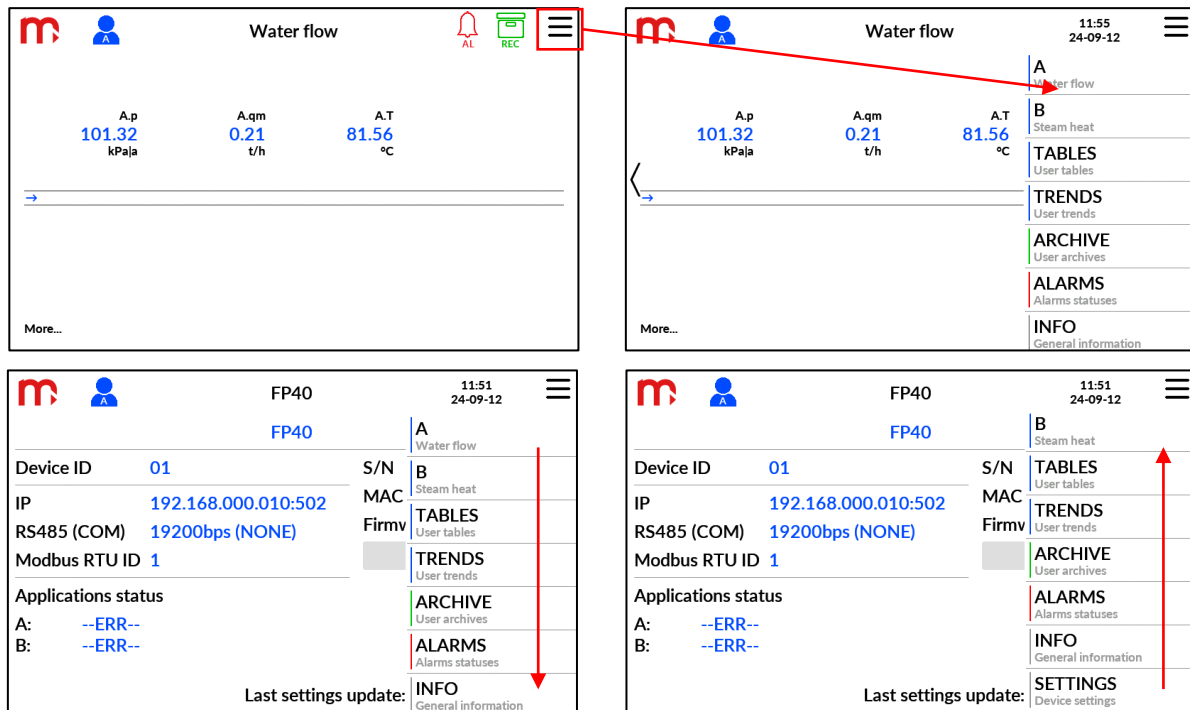

A <small>s-w open superheated</small>	Opens the main screen of application A (for more information, see Application screens).
B <small>Hall 2</small>	Opens the main screen of application B (for more information, see Application screens).
X <small>Additional Channels</small>	Opens the application X (for more information, see Additional channels).
TABLES <small>User Tables</small>	Opens the Table screen (for more information, see User Tables).
TRENDS <small>User Trends</small>	Opens the Trends screen (for more information, see User Trends).
ARCHIVE <small>User Archives</small>	Opens the Archive screen (for more information, see Archive screen).
ALARMS <small>Alarms Status</small>	Opens the Alarms screen (for more information, see Alarm Screen).
INFO <small>Device General Info</small>	Opens the About Device screen (for more information, see About Device).
SETTINGS <small>Device Settings</small>	Opens the Main Menu screen (for more information, see Main Menu).

4.2 Access control and passwords

4.2.1 Access control

The flow computer uses an access control module that limits the possibility of changing the operating parameters of the device and the ability to copy data from the device by unauthorized users.

The flow computer provides 5 levels of access. Identification of the login level is possible using the icon displayed in the title bar:

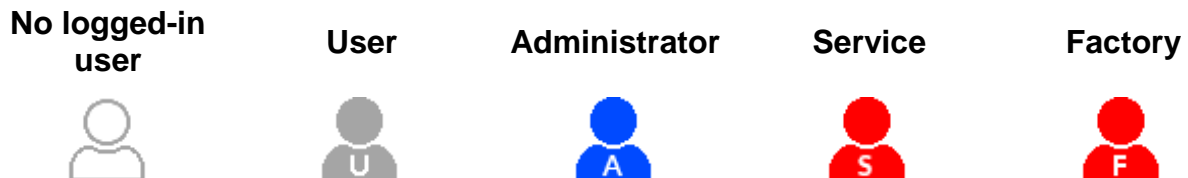

Three levels of access are sufficient to operate and configure the device: No logged in user, User and Administrator.

Below is a table showing access to the device's features depending on the level of access. The + sign indicates the functions normally available for the selected level, the * sign indicates the functions available depending on the settings.

Access level	No user logged-in	User	Administrator
Function			
Open the login window	+	+	+
Change a User's password		+	+
Change the Administrator password			+
Browse screens	+	+	+
Alarm confirmation		+	+
Resetting totalizers		+	+
Reset min. and max. values		+	+
Archive Control (stop/start archive)		*	+
Creating a new archive file		+	+
Copying archive files and print screen to USB		+	+
Deleting archive and print screen files			+
Displaying the event log			+
Display the settings windows in the Main Menu		+	+
Displaying service windows in the Main Menu			+
Change settings			+
Copy the settings file to USB			+
Loading the settings file from USB			+
Saving the print screen		+	+
Displaying the Service Test Window (TEST IO)	+	+	+

The User access protection may be deactivated. More information in chapter [Changing password](#)).

The Service level access may be required to set a new Admin password, to set the starting totalizer(s) value or re-calibration of analogue measurement inputs. It is possible to get the Service password from manufacturer. For more information, see procedure [Recover a lost password and obtain a service password](#)).

The Factory level contains functions available only to the manufacturer service procedures.

4.2.2 Log-in and Log-out

Logging in is possible in the Login window. Tapping the login status icon in the title bar opens the window.

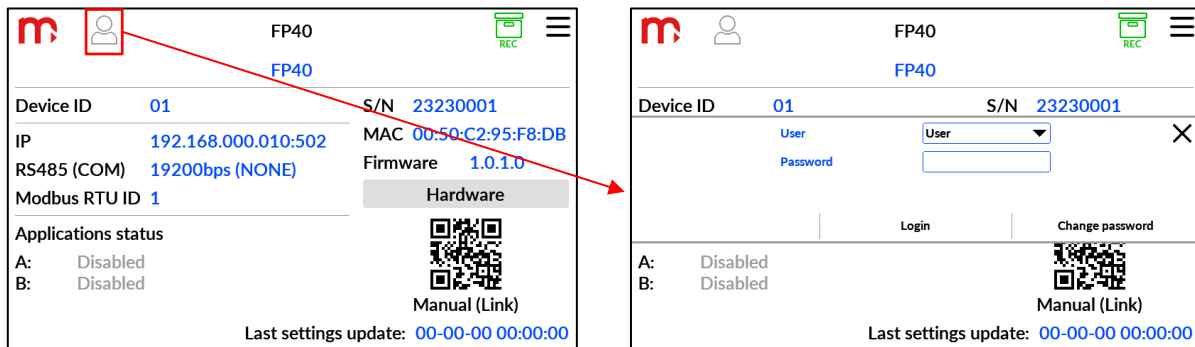

Appropriate access level from the drop-down list have to be selected and password entered. Tapping the 'Login' button confirms the operation.

The Administrator access is forbidden when LOCK2 hardware switch is activated. LOCK2 switch is located in rear panel for panel mount version device and in terminals compartment in panel mount version device.

Access level	Default password
User	0
Administrator	1

After the first login, it is recommended to change the default passwords. Logout, regardless of access level, occurs automatically after 5 minutes of inactivity. When logged off, the lowest access level is enabled. Logout after a shorter period of time is possible, tapping the 'Logout' button in the login window.

4.2.3 Changing the password

The password can be changed in the login window tapping the *Change password* button.

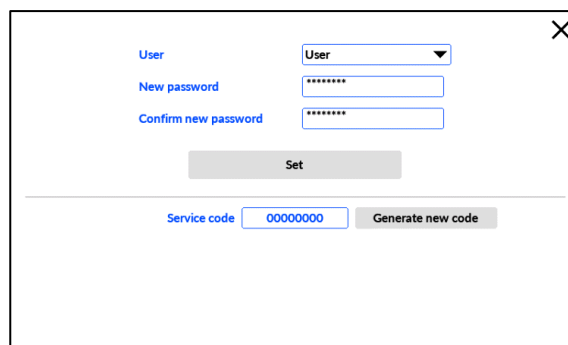

In the window that appears the required access level have to be selected and new password entered and confirmed. 'Set' button have to be tapped to accept the changes.

! The keyboard in the password change box allows to select only uppercase and lowercase letters and special characters. In the case of a password, it is not possible to enter letters specific to the selected language.

It is possible to disable the password for the User and/or Admin access level, when new password is left empty.

4.2.4 Recover of lost password and getting service password

When User password is lost, then Admin may set a new password. When Admin password is lost, then new password have to be set using Service level.

The Service password may be obtained from manufacturer. To generate new password the service code have to be delivered to manufacturer.

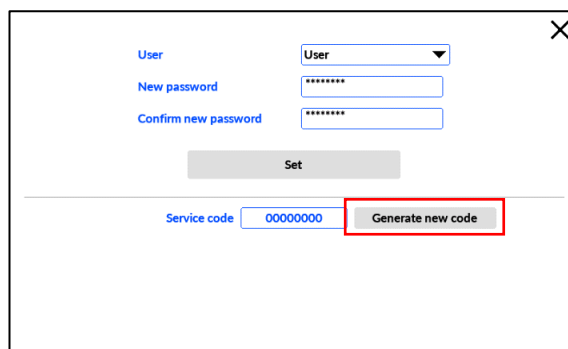

The Service Code field displays the 8-character unique code, when 'Generate new code' button is tapped. Manufacturer in response will generate matching password.

In similar way it is possible to get the One-time Factory password. It is valid to log-in once. When log-out, either manually or automatically after 5 minutes without activity, the password is deactivated. Device restart or power off-on does not affect the log-out.

! The Service password or One-time Factory password is valid until the new service code is generated.

4.3 Language change

Language change requires Administrator level (more information in the [Login chapter](#)).

The language selection is located in General settings screen (icon ) and tab General. In drop-down list there are available languages:

- EN (ENGLISH),
- DE (DEUTSCH),
- ES (ESPAÑOL),
- FR (FRANÇAIS),
- IT (ITALIANO),
- PL (POLISH),
- PT (PORTUGUÊS).

New language settings require confirmation (), and saving ().

4.4 First run

While starting the device for the first time with factory settings, the General Device Information screen appears. The drop-down menu contains only four buttons: ARCHIVE, INFO, SETTINGS, and I/O. All these screens are always available, regardless of the configuration of the settings. During factory settings, the screen of the device is dimmed after 5 minutes of inactivity. If the screen is dimmed, a blue LED on the front panel indicates that the device is operating.

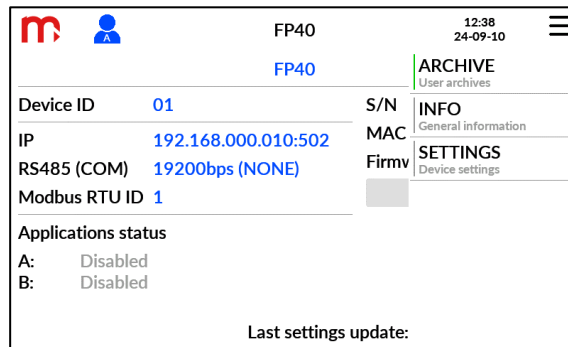

After delivery, the device has an English language set. After Restore factory settings, the device starts with the last used language. (See [Restore Factory settings](#) for more information).

In this state device is not ready for measurements and requires configuration as a next step ([CONFIGURE SETTINGS](#)).

4.5 Screens

The number of available screens and their details varies depending on the device configuration and settings. Some screens (main screens) are available from Main Menu buttons or title bar icons. Others (detailed information screens) are available by tapping active areas in currently displayed screens.

4.5.1 Application A and B screens

The Application A or B screen is brought to display by tapping the A or B button from the Main Menu. The buttons A and/or B are available when application A and/or B is configured.

The Application Home Screen contains a simplified synoptic application schema. The process values displayed on the screen are defined automatically. Flowmeter, thermometer, and pressure gauge pictures are displayed if the corresponding channels are configured as input measurements.

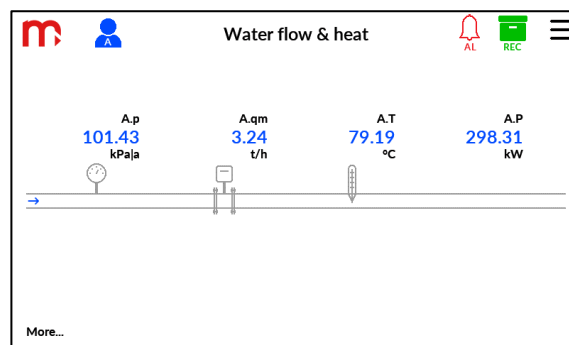

A detailed description of the available measuring systems and the corresponding simplified screens is described in the chapter [Types of measuring systems A and B](#).

The screen contains a **More....** button. Pressing the button displays Application Table window. The table contains all process values billed in the application. Tapping the x closes the window and returns to Application Home Screen.

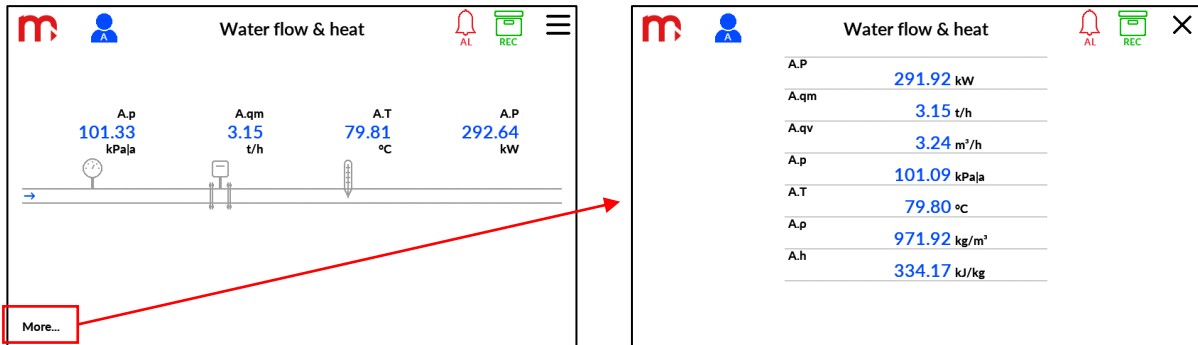

Tapping the process value pops up the Single Result window with more detailed information on this channel. To close the single result window, the x have to be tapped.

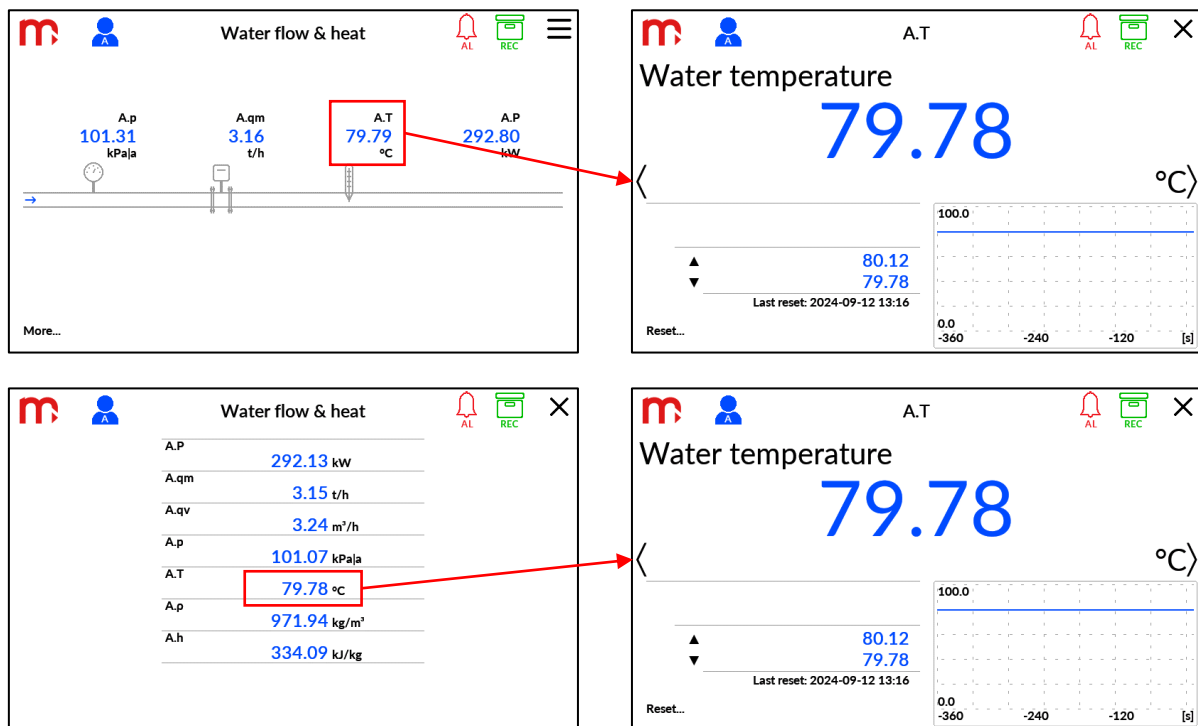

Only the channel symbol (e.g. A.T) is displayed in Application Home Screen and Application Table window. The symbol is unique for every process value in the device and cannot be edited. But every process value may be added an individual description and it is displayed in the Single Result window, in the [User Table](#) screens and in the User [Trends screen](#).

4.5.2 Application X (auxiliary channels) screen

The Application X screen is brought to display by tapping the X button from the Main Menu. The button X is available when at least one auxiliary channel is configured.

The Application X screen contains a table with all active auxiliary channels (max. 16 channels). The order and arrangement of the channels in the table is fixed and cannot be edited. If the channel is not enabled, the space in the table will be left blank.

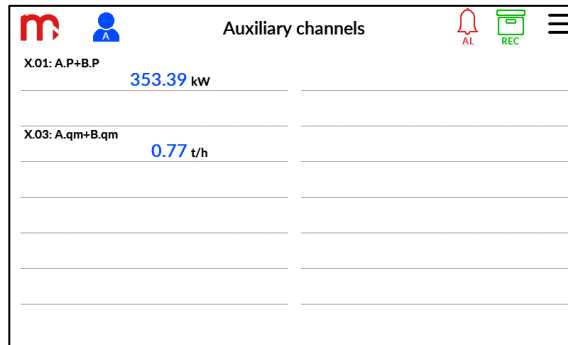

For auxiliary channels the Single Result is also available, in very similar way as for application A and B. To close the single result window, the x have to be tapped.

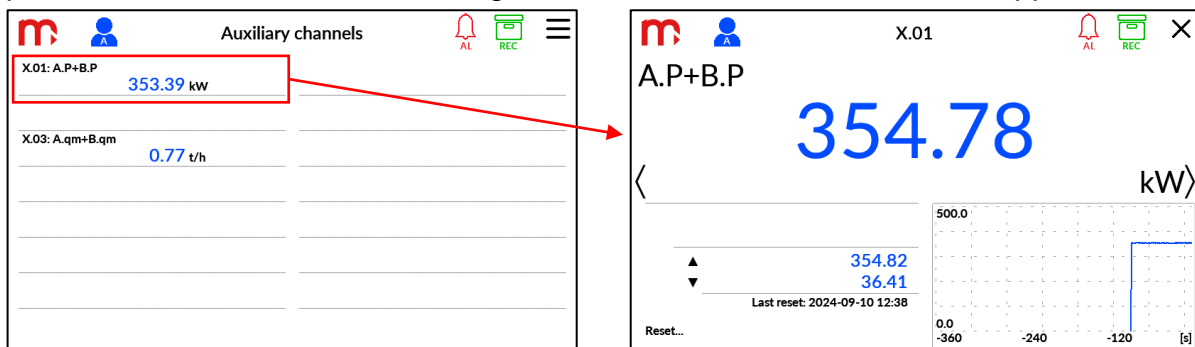

4.5.3 Single Result

This window is the most detailed screen displayed for a single process value.

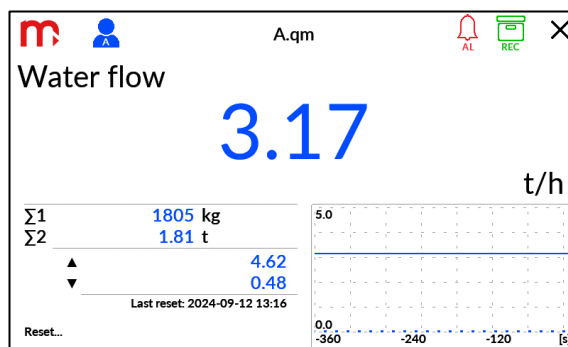

The channel symbol (e.g. A.qm) at the top allows to identify the application and process value.

The *Single Result* window displays: channel symbol, user channel description, process value, channel unit, totalizer 1 and 2 values (if configured as active), minimum and maximum values and trend from the last 360 seconds.

At the bottom left corner of the screen there is a **Reset....** button. Pressing it opens a window with reset options for totalizers and maximum and minimum values: for current channel only, for all channels from current application or all channels from all applications.

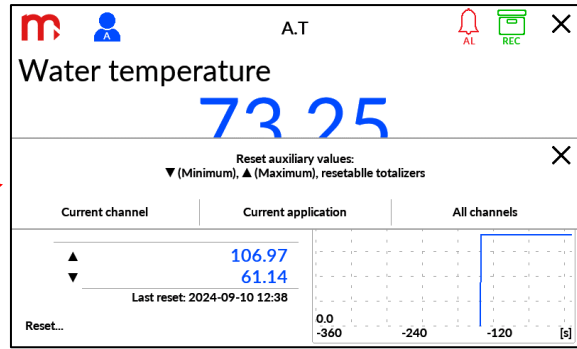
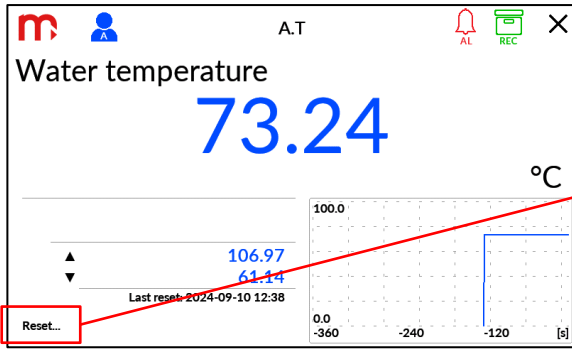

Only totalizers configured as resettable will be reset. For execution of this function User login is required. On the screen there is also a date and time stamp from last reset.

The trend chart box contains a graph from the last 360 seconds (minimized chart). Tapping the chart causes maximizing it to full screen size. Minimizing the chart back requires tapping the chart again.

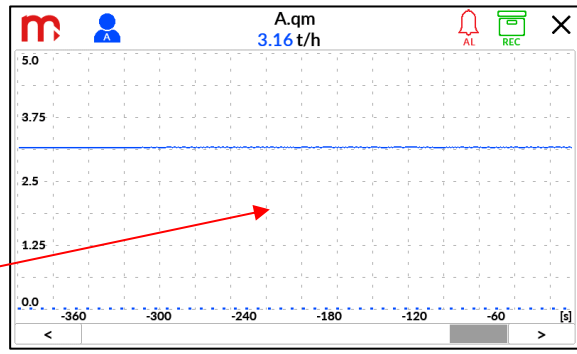
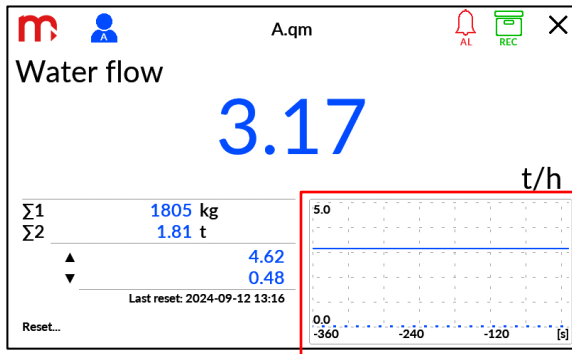

In full screen mode it is possible to display the trend line from the last hour with a slider at the bottom of the screen.

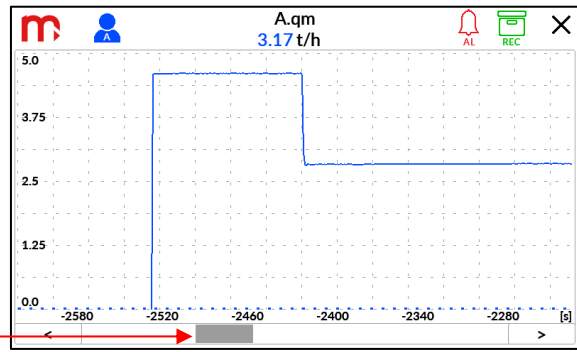
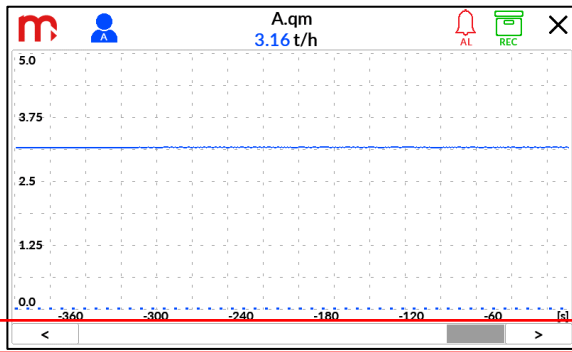

When the single result window is opened, the two cursors are displayed at the sides: < (scroll previous) and > (scroll next). Using the cursors it is possible to view other channels the current application. The cursors disappear after five seconds if not used. After pressing touchscreen they will appear.

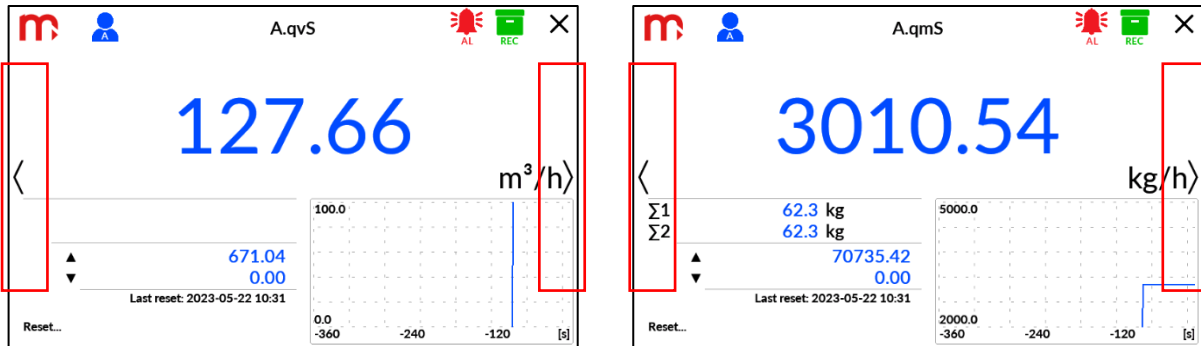

4.5.4 User Tables

To open User Tables select TABLES button from the Main Menu. The button is available when at least one user table is configured.

Up to 6 user tables may be configured. Each table is built from a 16 element in a 2x8 layout. The process values, totalizers, minimum or maximum values may be displayed in any mixed configuration from applications A, B and X. Also empty cells may be left for clear readout and user preferences.

For each table element, value, unit, and channel name are displayed. If channel name is not entered, then the channel symbol is displayed instead.

All heat & flow	
Water heat	297.86 kW
Water flow	3.24 t/h
B.P	2751.24 kW
B.qm	3.17 t/h
Σ1: Water heat	0.04 GJ
Σ2: Water heat	39 MJ
Σ1: Water flow	0.12 t
Σ2: Water flow	118 kg
Σ1: B.P	0.36 GJ
Σ2: B.P	362 MJ
Σ1: B.qm	0.12 t
Σ2: B.qm	116 kg

Pressing the value in the table pops up the [Single Result](#) with more detailed information on this channel. To close the single result window, the x have to be tapped.

All heat & flow	
Water heat	297.86 kW
Water flow	3.24 t/h
B.P	2751.24 kW
B.qm	3.17 t/h
Σ1: Water heat	0.04 GJ
Σ2: Water heat	39 MJ
Σ1: Water flow	0.12 t
Σ2: Water flow	118 kg
Σ1: B.P	0.36 GJ
Σ2: B.P	362 MJ
Σ1: B.qm	0.12 t
Σ2: B.qm	116 kg

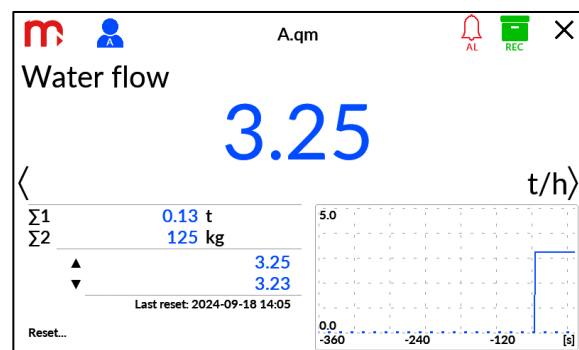

To switch between different User Tables, press scroll left (<) or right (>) cursors available on the sides of the screen. The arrows disappear after five seconds if not used. To recall them requires tapping the screen. After pressing touchscreen they will appear.

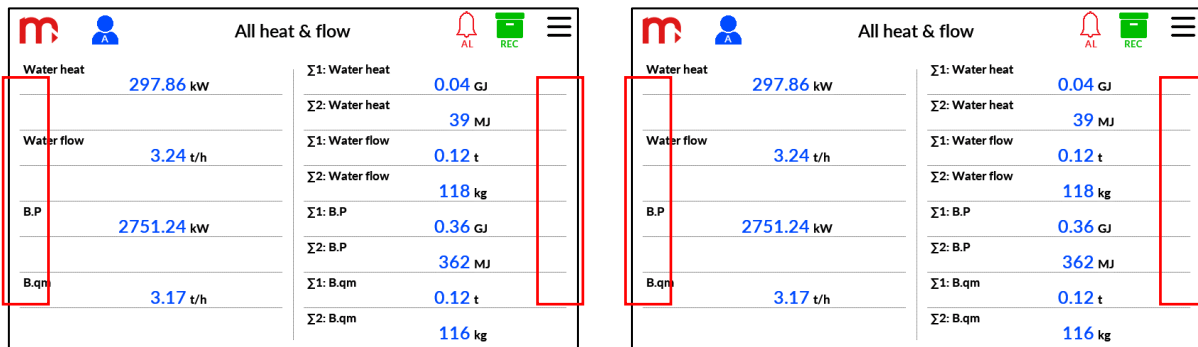

4.5.5 User Trends

To open User Trends select TRENDS button from the Main Menu. The button is available when at least one user trend is configured.

Up to 6 user trends screens may be configured. Each chart may have up to 6 trends. Only process values may be shown as a trend. Any mixed configuration from applications A, B and X is possible.

User Trends screens display a time window of 360 seconds (if the legend is disabled) or 240 seconds (if the legend is enabled).

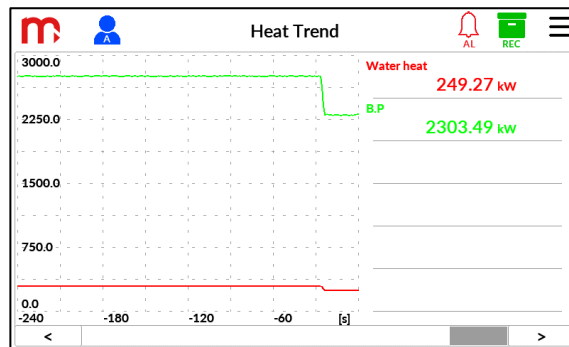

In the User Trends screens it is possible to display the trend line from the last hour using the slider at the bottom of the screen.

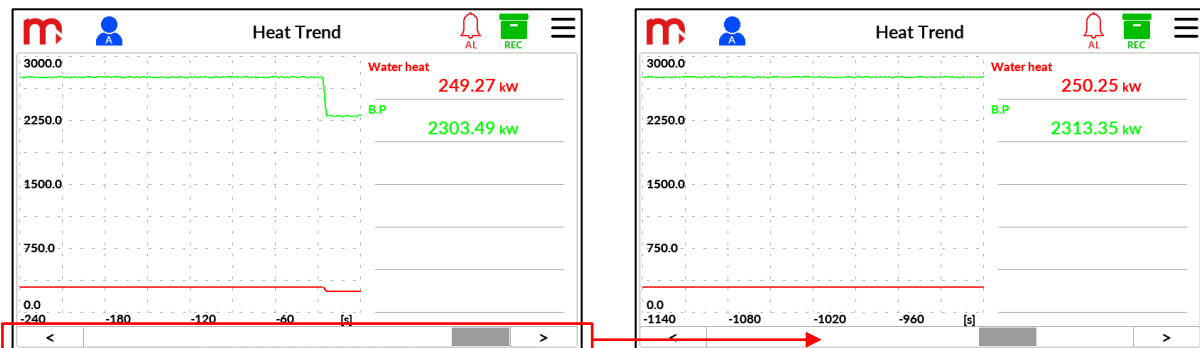

The legend displays the value, unit, and channel name. If channel name is not entered, then the channel symbol is displayed instead. Pressing on the chart field shows/hides the legend.

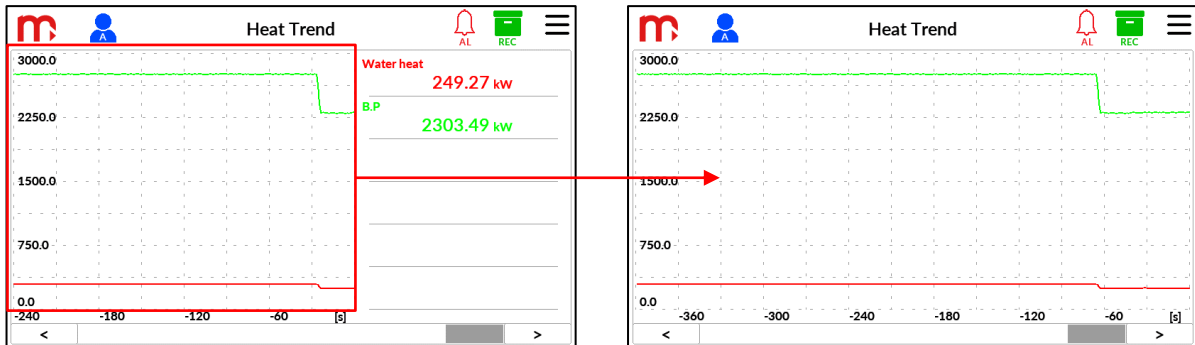

Pressing the value in the legend opens the [Single Result](#) window with more detailed information on this channel.

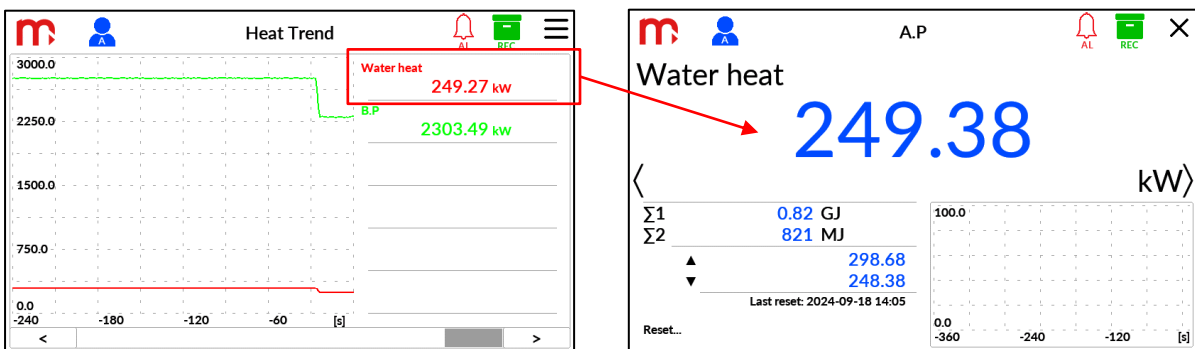

To switch between different User Trends, press scroll left (<) or right (>) cursors available on the sides of the screen. The arrows disappear after five seconds if not used. To recall them requires tapping the screen. After pressing touchscreen they will appear.

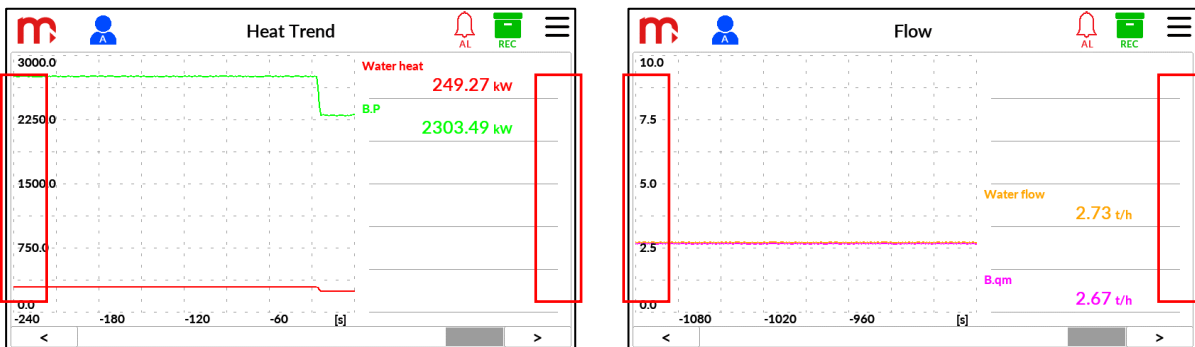

4.5.6 Archive screen

To open Archive select ARCHIVE button from the Main Menu. or the archive icon in the Title Bar. The button in Main Menu is always available. The description of the archiving processes are described in the [ARCHIVE](#) chapter.

The upper part of the screen contains information on the archive configuration: the current archive file number and type of the archive (e.g. Weekly), the two frequencies of archiving for process data (active in blue) and one for totalizers archive. There is also an indicator of the internal memory usage. For safety of archived data user should successively copy the archive files. It is also recommended to delete old files to keep enough free space for new data. (For more information, see [Writing and reading files using the USB port](#)). When the memory capacity reaches 70%, the Internal Memory Usage indicator turns yellow, and when it reaches 90% it turns red. After reaching 95%, the memory will be automatically cleared to 90% by deleting the oldest files (more information in the [ARCHIVE](#) chapter).

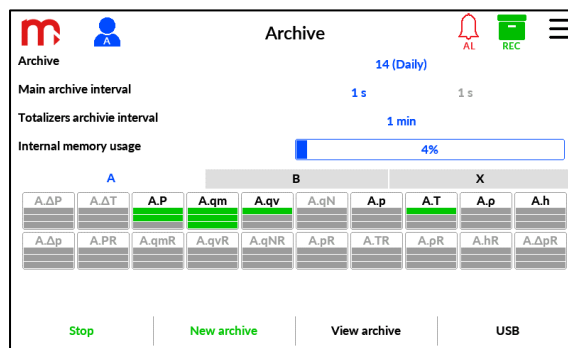

At the lower part of the screen there is information on archive configuration. Each channel has archive status indicator with channel symbol and three bars beneath. Upper bar represents process value, two lower bars represent two totalizers corresponding to the process value. If channel is not active, the whole indicator is grey. The status information is coded in colours:

- green for archived value,
- grey for not archived value.

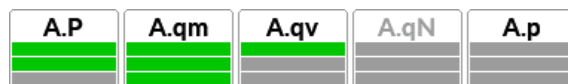

At the bottom of the Archive screen there are four control buttons:

- **Stop/Start** to stop/resume archiving
- **New archive** to create a new archive file
- **View archive** to view process values archive file
- **USB** to open USB window

Note:

Above operations may require User or Admin login.

It is required to stop archiving process before creating new archive file. After creating a new archive file, it is necessary to start archiving.

From the Archive screen it is possible to switch over directly to the USB window to copy selected archive files to external flash memory and delete old archive files from internal memory. (More information in chapter [Writing and reading files using the USB port](#)).

4.5.7 Alarms status screen

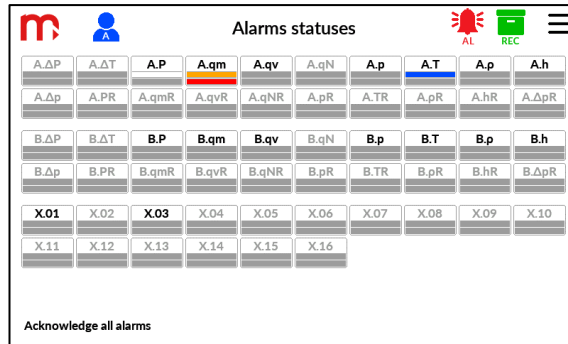

The Alarms status screen is brought to display by tapping the ALARMS button from the Main Menu. The button is available when at least one alarm threshold is configured.

The screen shows all possible alarm states for all channels in one screen. Each channel has its own indicator with channel symbol in the top.

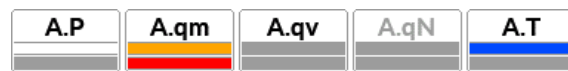

There are two bars in the indicator representing alarm thresholds I and II. Alarm status is coded in bar colour:

- white/black alarm threshold not activated (no alarm)
- blue, green, orange or red^[1] alarm threshold activated (alarm on)
- grey alarm threshold disabled (not configured)

[1]: To alarm threshold the extra alarm colour may be assigned: green, orange or red. Then this colour is shown in the indicator bar, when alarm is activated. If extra colour was not assigned, then standard blue colour is used to show alarm activation. Not configured channels have whole indicators coloured in grey.

4.5.7.1 Alarm acknowledgement (Alarm mode)

Every alarm may work in Control mode or Alarm mode. Alarm mode requires to acknowledge alarm by user when activated. To indicate new alarm, the alarm icon in the title bar will blink. Source of alarm verification and alarm acknowledge is possible only in Alarm status screen. At the bottom of the screen there is **Acknowledge all alarms** button to confirm all alarms.

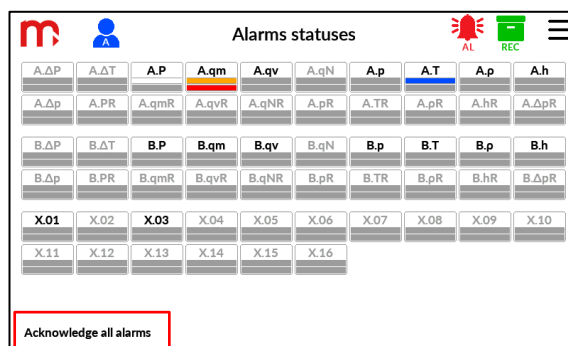

All activated and not acknowledged alarms are blinking (blue, green, orange or red, depending on configuration). Alarms acknowledged or in control mode are constantly on, if are still activated. In this way user may learn which alarms are new (blinking), and which of them are still activated (continuously on) or not activated (white).

4.5.7.2 Alarms indication in other screens

If extra colour (green, orange or red) is assigned to alarm threshold, then the related process value changes its colour when alarm threshold is crossed over (in both alarm and control modes).

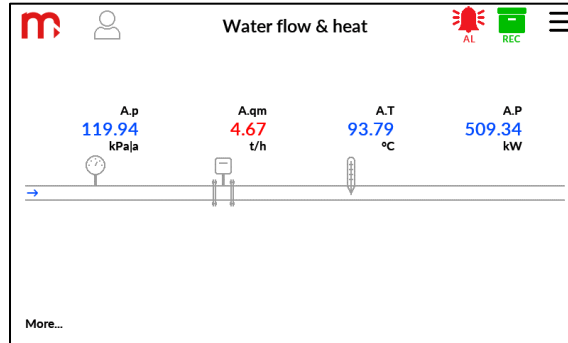

If an alarm has been configured, an additional dotted line is displayed in the chart field in the result window indicating the alarm level. The line is in the colour selected for the alarm.

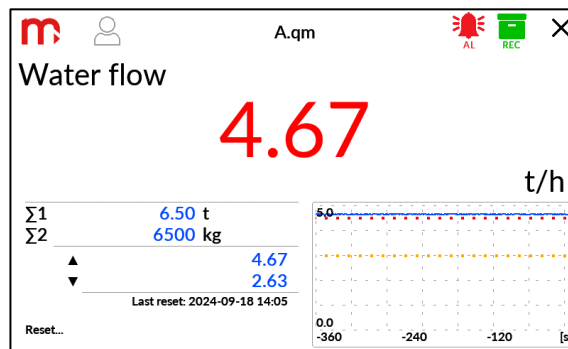

4.5.8 Device Information screen

Device Information screen is selected by tapping the INFO button from the drop-down menu. This screen contains information about the device: model, device description, device ID, serial number, MAC, firmware version, IP address with Modbus TCP port, RS485 (COM) communication parameters and Modbus RTU address. The screen contains a QR code with link to current User Manual.

After pressing the Hardware button, a window will open with information about the installed IO cards.

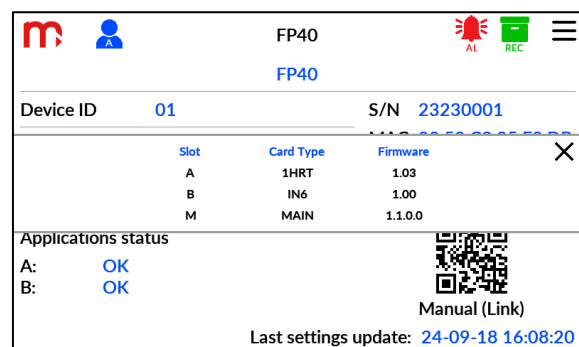
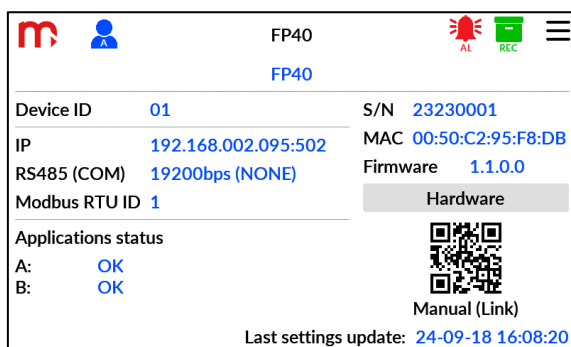

The screen also contains general information on the operating status on measuring applications A and B:

Disabled	The application is disabled (not configured and not used).
OK	The application is enabled and all values are calculated correctly.
OK	The application is enabled and has the correct status. The process values are calculated, but some deviations are detected. (E.g. failure value is used instead of measurement, cut-off for low flowrate activated, extrapolation of steam values is used out of steam tables, etc.).
--ERR--	The application is enabled and has an incorrect status. At least one process value has error status (--ERR--).

4.5.9 Settings screen

The Settings screen is opened by tapping the SETTINGS button from the Main Menu. The description of the archiving processes are described in details in the [SETTINGS AND DEVICE CONFIGURATION](#) chapter.

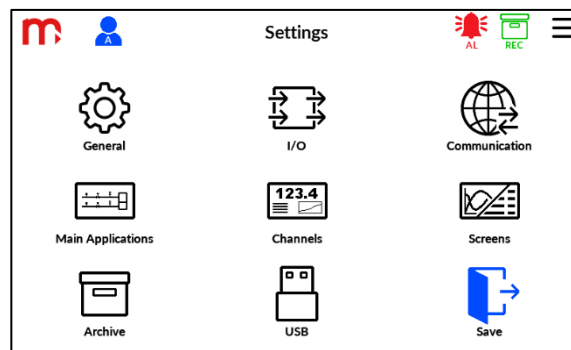

4.6 Print Screen

Print Screen is a service function. It may be helpful during commissioning or tests. To take a screenshot, the BTL button has to be used. It is located on the rear panel.

During the operation, the screen will remain inactive for a few seconds, and the process will be signalled by a blue LED located on the front panel of the device. Screenshot is saved in internal memory as a bitmap with date, time and successive number as a file name. (rrmdd_hhmm_00.bmp, rrmdd_hhmm_01.bmp, ...).

Files may be copied or deleted in USB window.

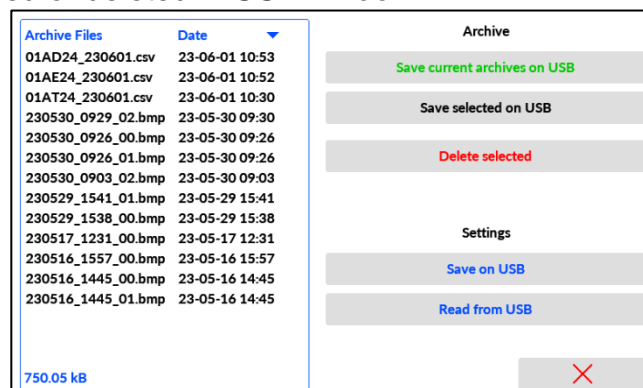

4.7 Write and read files via USB port

Writing and reading files using the USB port is only possible in a USB window. There are two ways to go to the USB window:

- in the Archive screen, pressing the USB button
- in the Settings screen, pressing the USB icon

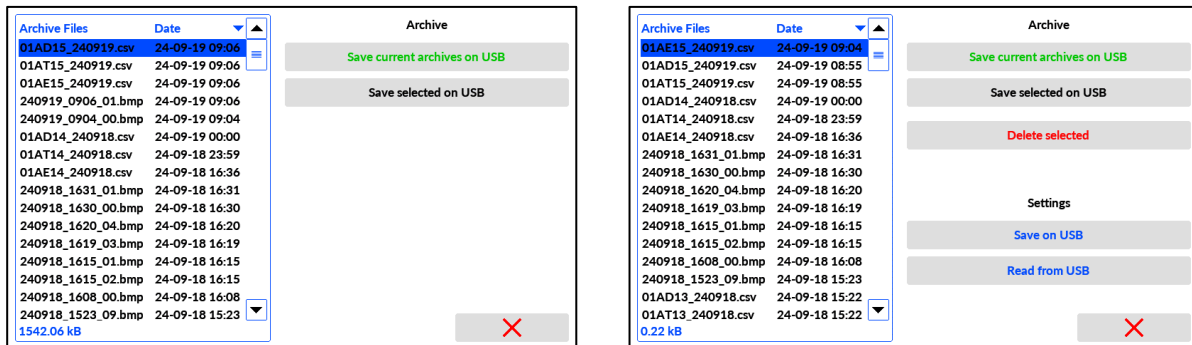

On the left side of the window there is a list of archive files and screenshots (print screen) saved in the internal memory of the device. On the right side of the window there are function buttons. Depending on the access level, it is possible to:

- Save current archive files to USB
- Save selected file on USB
- Delete archive file
- Save parameters on USB (Administrator)
- Read new parameters from USB (Administrator)

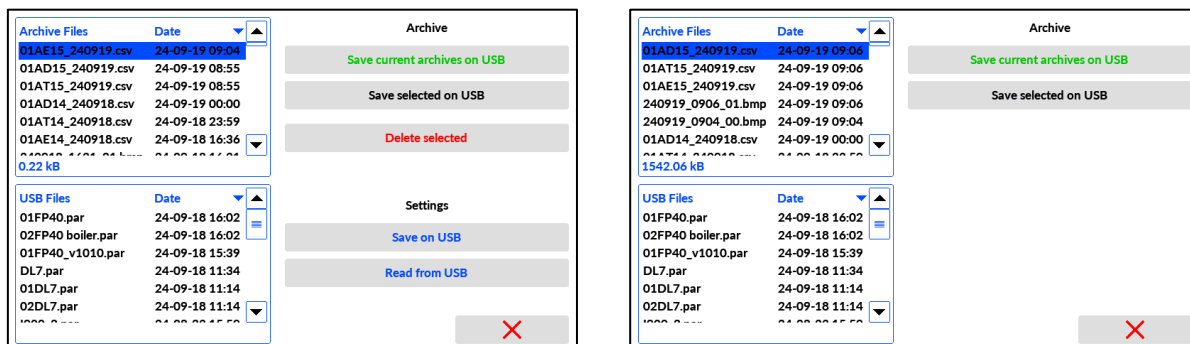

After connecting the external memory, on the left side of the window a box will be displayed containing the settings files recorded on the flash drive (files in *par* format).

To delete a file, select the file tap the *Delete selected* button. It is possible to select only one file a time.

Note:

To write and read files via USB port, external flash memory must be formatted in FAT32. Compatibility with all USB memory devices is not guaranteed.

5 MEASUREMENTS APPLICATIONS

5.1 Medium Types

The device supports the following types of media: water, other liquid media, superheated steam, saturated steam and technical gases.

5.1.1 Water

The density and enthalpy of water are calculated according to IAPWS-IF97 for pressures of 0.02 MPa_a to 20.0 MPa_a and temperature 0 °C to 350 °C. The enthalpy is calculated relative to the entered reference point for pressure and temperature.

The water temperature should always be measured, while the pressure can be measured or it can be entered as a constant value. If due to measurement inaccuracies, the measured water temperature is slightly higher than the boiling point at a given pressure, the density and enthalpy is calculated for the boiling point. However, if the measured temperature is higher more than 10 °C above the boiling point, then the error is indicated instead of the density and enthalpy values, and all other results calculated on their basis in consequence. More information in chapter [Hierarchy of process values and failure indication](#).

For steam applications with condensate return, the pressure of the condensate can be measured, be considered equal to the steam pressure, or entered as a constant value. The temperature of the condensate can be measured or it can be assumed be at boiling point. Then the temperature is taken from the steam saturation curve.

5.1.2 Other liquids

Other liquids measurements are based on Medium User Table. Depending on needs, the table has data on density as a function of temperature or pressure or temperature and pressure. It also may contain enthalpy or specific heat or calorific for energy of combustion measurements. If measured values exceeds Medium User Table calculation will be extrapolated based on table marginal values.

5.1.3 Steam, superheated and saturated

The steam density and enthalpy are calculated according to IAPWS-IF97 in range:

- 52 °C to 800 °C and 0.02 MPa_a to 16.5 MPa_a for superheated steam
- 0 °C to 372 °C for saturated steam (with temperature measured)
- 0.02 MPa_a to 16.5 MPa_a for saturated steam (with pressure measured)

The enthalpy is calculated relative to the entered reference point for pressure and temperature.

For superheated steam applications, both pressure and temperature should be measured. If due to measurement inaccuracies, the measured steam temperature is slightly lower than the condensation temperature at a given pressure, then the density and enthalpy is calculated at the condensation temperature point. However, if the measured temperature is more than 10 °C lower than the condensation temperature, then the error is indicated instead of the density and enthalpy values, and all other results calculated on their basis in consequence. For more information, see chapter [Hierarchy of process values and failure indication](#).

For saturated steam applications either pressure or temperature is measured. The other value is calculated using the saturation curve. If user need to have both, pressure and temperature measured, then only one value (p(T) or T(p)) is used for calculating steam parameters, and the other one may be displayed as auxiliary value.

5.1.4 Gas

The device may measure the flow or the flow and energy of technical gases. The gas pressure and temperature may be measured or entered as a constant value. The actual gas density is calculated according to the ideal gas equation relative to density at reference conditions (pressure and temperature). It is also possible to determine density and enthalpy using User Medium Table. For heat or combustion energy User Medium Table have to be used with enthalpy, specific heat or calorific of the gas.

The fuel gas may also be measured if approximate measurement based on ideal gas equation or User Medium Table is accepted.

5.2 Process values symbols

Channel symbols are fixed and cannot be changed. Each symbol is unique and identifies channel in the device.

5.2.1 Application identifier

Each channel symbol has a prefix indicating the layout A, B or X separated by a dot from the symbol indicating the process value. E.g. 'A.qm' means that process value qm belongs to application A.

5.2.2 Channel symbols in application A and B

Depending on the configuration, a certain list of channels are available in every application. The full list of possible symbols is as below:

ΔP	- heat flowrate difference between supply and return
ΔT	- temperature difference between supply and return
P/PS	- heat flowrate / heat flowrate at supply
qm/qmS	- mass flowrate / mass flowrate at supply
qv/qvS	- volumetric flowrate / volumetric flowrate at supply
qN/qNS	- volume standardized flowrate / volume standardized flowrate at supply
p/pS	- pressure / pressure at supply
T/TS	- temperature / temperature at supply
$\rho/\rho S$	- density / density at supply
h/hS	- enthalpy / enthalpy at supply
Δp	- pressure difference at differential pressure device
ΔpS	- pressure difference at differential pressure device at supply
PR	- heat flowrate at return
qmR	- mass flowrate at return
qvR	- volume flowrate at return
qNR	- volume standardized flowrate at return
pR	- pressure at return
TR	- temperature at return
ρR	- density at return
hR	- enthalpy at return
ΔpR	- pressure difference at differential pressure device at return

5.2.3 Channel symbols in application X

There are 16 channels available in application X. Those auxiliary channels are user configurable and their symbols are numbers from 01 to 16 (e.g. X01, X11).

5.2.4 Symbols for totalizers and min / max values

Each process value have minimum or maximum value, some may also be totalized. In order to distinguish these values an additional symbol is used in the Single Result screen or in the User Tables and User Trends:

- PV** - channel process value
- MIN** - Minimum value (marked by ▼)
- MAX** - Maximum value (marked by ▲)
- Σ1** - Totalizer 1
- Σ2** - Totalizer 2

E.g. Σ1:A.qm – means mass flowrate first totalizer in application A, and ▲:X.01 – means maximum value for auxiliary channel 01 in application X.

5.3 Available types of main measuring applications

The chapter presents sample screenshots of Main Application Screens. Screens may vary depending on how process values are measured.

The screens contain gauge icons. If the value is measured using a measurement card, a gauge icon will be displayed:

Temperature



Pressure



Flow



For each layout, an arrow is displayed indicating the flow direction, indicating a higher (red) or lower (blue) temperature. The arrows allow to verify the application: heating (supply: →, return: ←) or cooling (supply: →, return: ←).

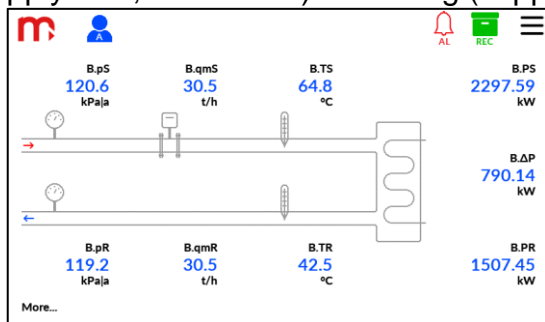

heating system – the supply temperature is higher than the return temperature

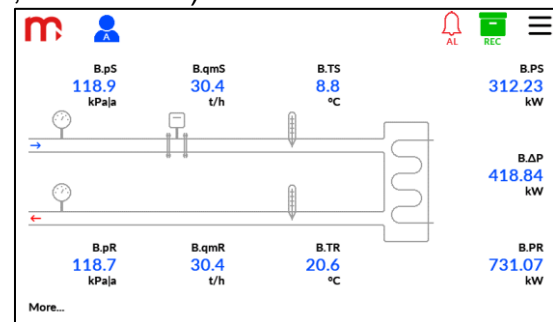

cooling system – the supply temperature is lower than the return temperature

Note:

The layout is a synoptic schematic of the application and doesn't show the real pipeline and sensors arrangement. The following sections provide detailed information on the values determined in various types of systems.

5.3.1 Liquid Flow

Liquid flow allows to calculate compensated flow according to temperature and/or pressure measurements. Typical application for water uses build in density tables. For other medium than water, the user medium table have to be prepared and uploaded to the device.

SHORT NAME	Liquid flow
FULL NAME	Liquid flow measurement
TYPE OF MEDIUM	Liquid
ADDITIONAL SETTINGS	-
LAYOUT DIAGRAM	
INPUT PROCESS VALUES	<ul style="list-style-type: none"> • pressure (p) • temperature (T) • mass flowrate (qm) or volumetric flowrate (qv) or differential pressure (Δp)
COMPUTED PROCESS VALUES	<ul style="list-style-type: none"> • mass flowrate (qm) + optional totalizers • volumetric flowrate (qv) + optional totalizers • pressure (p) • temperature (T) • density (ρ) • differential pressure (Δp) – only if differential pressure device was chosen

5.3.2 Liquid Heat

Liquid heat allows to calculate compensated flow and heat according to temperature and/or pressure measurements. Typical application for water uses build in density and enthalpy tables. For other medium then water, the user medium table have to be prepared and uploaded to the device. For heat calculations enthalpy or specific heat have also to be entered in the user table. The application may also be used to calculate combustion heat. Then calorific of the liquid have to be entered instead of enthalpy.

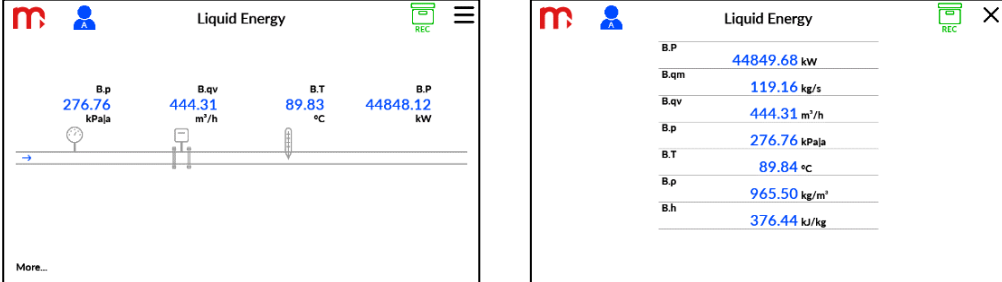
SHORT NAME	Liquid heat
FULL NAME	Flow and liquid heat measurement
TYPE OF MEDIUM	Liquid
ADDITIONAL SETTINGS	-
LAYOUT DIAGRAM	
INPUT PROCESS VALUES	<ul style="list-style-type: none"> • pressure (p) • temperature (T) • mass flowrate (qm) or volumetric flowrate (qv) or differential pressure (Δp)
COMPUTED PROCESS VALUES	<ul style="list-style-type: none"> • heat flowrate (P) + optional totalizers • mass flowrate (qm) + optional totalizers • volumetric flowrate (qv) + optional totalizers • pressure (p) • temperature (T) • density (ρ)

5.3.3 Liquid delta Heat (Closed loop)

Liquid Δ Heat (Closed loop) allows to calculate compensated flow and heat according to temperature and/or pressure measurements. Flowrate is measured only at supply or return pipeline, assuming that there is no liquid loss in the application. Typical application for water uses build in density and enthalpy tables. For other medium then water, the user medium table have to be prepared and uploaded to the device. For heat calculations density and enthalpy or specific heat have also to be entered in the user table.

SHORT NAME	Liquid Δ Heat (closed loop)
FULL NAME	The flow and differential heat of a liquid in a closed installation
TYPE OF MEDIUM	Supply: Liquid Return: Liquid
ADDITIONAL SETTINGS	Heating system / Cooling system
LAYOUT DIAGRAM	
INPUT PROCESS VALUES	<ul style="list-style-type: none"> • pressure at supply (pS) • temperature at supply (TS) • mass flowrate at supply (qmS) or volumetric flowrate at supply (qvS) • differential pressure at supply (ΔpS) • or mass flowrate at return (qmR) • or volumetric flowrate at return (qvR) • or differential pressure at return (ΔpR) • pressure at return (pR) • temperature at return (TR)
COMPUTED PROCESS VALUES	<ul style="list-style-type: none"> • heat flowrate difference between supply and return (ΔP) + optional totalizers • temperature difference between supply and return (ΔT) • heat flowrate at supply (PS) + optional totalizers • mass flowrate at supply (qmS) + optional totalizers • volumetric rate flow at supply (qvS) + optional totalizers • pressure at supply (pS) • temperature at supply(TS), • density at supply (ρS), • enthalpy at supply (hS), • heat flowrate at return (PR) + optional totalizers • mass flowrate at return (qmR) + optional totalizers • volumetric flowrate at return (qvR) + optional totalizers • pressure at return (pR) • temperature at return (TR) • density at return (ρR) • enthalpy at return (hR)

5.3.4 Liquid delta Heat

Liquid Δ Heat allows to calculate compensated flow and heat according to temperature and/or pressure measurements. Flowrate is measured in both pipelines. Typical application for water uses build in density and enthalpy tables. For other mediums, the user medium table have to be prepared and uploaded to the device. For heat calculations density and enthalpy or specific heat have also to be entered in the user table.

SHORT NAME	Liquid Δ Heat
FULL NAME	The flows and differential heat of a liquid with separate supply and return flowrates
TYPE OF MEDIUM	Supply: Liquid Return: Liquid
ADDITIONAL SETTINGS	Heating system / Cooling system
LAYOUT DIAGRAM	
INPUT PROCESS VALUES	<ul style="list-style-type: none"> • pressure at supply (pS), • temperature at supply (TS), • mass flowrate at supply (qmS) or volumetric flowrate at supply (qvS) or differential pressure at supply (ΔpS), • pressure at return (pR), • temperature at return (TR), • mass flowrate at return (qmR) or volumetric flowrate at return (qvR) or differential pressure at return (ΔpR)
COMPUTED PROCESS VALUES	<ul style="list-style-type: none"> • heat flowrate difference between supply and return (ΔP) + optional totalizers • temperature difference between supply and return (ΔT) • heat flowrate at supply (PS) + optional totalizers • mass flowrate at supply (qmS) + optional totalizers • volumetric flowrate at supply (qvS) + optional totalizers • pressure at supply (pS) • temperature at supply (TS), • density at supply (ρS), • enthalpy at supply (hS), • heat flowrate at return (PR) + optional totalizers • mass flowrate at return (qmR) + optional totalizers • volumetric flowrate at return (qvR) + optional totalizers • pressure at return (pR) • temperature at return (TR) • density at return (ρR) • enthalpy return (hR)

5.3.5 Steam net Heat

Steam net Heat allows to calculate compensated flow and heat for saturated or superheated steam. In case of saturated steam operation only one parameter is measured, either temperature or pressure. The second value is calculated based on the build-in saturation curve.

SHORT NAME	Steam net heat	
FULL NAME	The flow and heat of steam measurement	
TYPE OF MEDIUM	Superheated steam (temperature and pressure measurement)	Saturated steam (temperature or pressure measurement)
ADDITIONAL SETTINGS	-	Dry steam should be introduced
LAYOUT DIAGRAM		
INPUT PROCESS VALUES	<ul style="list-style-type: none"> • pressure (p), • temperature (T) • mass flowrate (qm) or volumetric flow rate (qv) or differential pressure (Δp) 	<ul style="list-style-type: none"> • pressure (p) or temperature (T) • mass flowrate (qm) or volumetric flowrate (qv) or differential pressure (Δp)
COMPUTED PROCESS VALUES	<ul style="list-style-type: none"> • heat flowrate of steam (P) + optional totalizers • mass flowrate of steam (qm) + optional totalizers • volumetric flowrate of steam (qv) + optional totalizers • pressure (P) • temperature (T) • density (ρ) 	

5.3.6 Steam – Condensate delta Heat (Closed loop)

Steam-Condensate Δ Heat (Closed loop) allows to calculate compensated flow and heat for superheated or saturated steam including condensate billing. Closed loop application assumes no steam or condensate loss. Flowrate may be measured in supply (steam) or return (condensate) pipeline. In case of saturated steam operation only one parameter is measured, either temperature or pressure. The second value is calculated based on the build-in saturation curve.

SHORT NAME	Steam-Cond. Δ Heat (closed loop)	
FULL NAME	The flow and differential heat in a closed steam-condensate installation	
TYPE OF MEDIUM	Supply: Superheated steam Return: Condensate	Supply: Saturated steam Return: Condensate
ADDITIONAL SETTINGS	Steam dryness may be entered	
LAYOUT DIAGRAM	<p>Steam closed circuit</p> <p>Supply: A.pS 500.73 kPaJa, A.qvS 456.78 m³/h, A.TS 229.04 °C Return: A.pR 290.72 kPaJa, A.qmR 1007.93 kg/h, A.TR 85.22 °C</p> <p>Differential: A.ΔP 716.84 kW, A.PR 99.95 kW</p>	<p>Steam closed circuit</p> <p>Supply: A.pS 2754.58 kPaJa, A.qvS 456.27 m³/h, A.TS 229.16 °C Return: A.pR 1075.85 kPaJa, A.qmR 6285.21 kg/h, A.TR 85.28 °C</p> <p>Differential: A.ΔP 4268.59 kW, A.PR 624.81 kW</p>
INPUT PROCESS VALUES	<ul style="list-style-type: none"> pressure at supply (pS) temperature at supply (TS) mass flowrate at supply (qmS) or volumetric flowrate at supply (qvS) or differential pressure at supply (ΔpS) or mass flowrate at return (qmR) or volumetric flowrate at return (qvR) or differential pressure at return (ΔpR) pressure at return (pR) temperature at return (TR) 	<ul style="list-style-type: none"> pressure at supply (pS) or temperature at supply (TS) mass flowrate at supply (qmS) or volumetric flowrate at supply (qvS) or differential pressure at supply (ΔpS) or mass flowrate at return (qmR) or volumetric flowrate at return (qvR) or differential pressure at return (ΔpR) pressure at return (pR) temperature at return (TR)
COMPUTED PROCESS VALUES	<ul style="list-style-type: none"> heat flowrate difference between supply and return (ΔP) + optional totalizers temperature difference between supply and return (ΔT) heat flowrate at supply (PS) + optional totalizers mass flowrate at supply (qmS) + optional totalizers 	

COMPUTED PROCESS VALUES	<ul style="list-style-type: none">• volumetric flowrate at supply (qvS) + optional totalizers• pressure at supply (pS)• temperature at supply (TS)• density at supply (ρS)• enthalpy at supply (hS)• heat flowrate at return (PR) + optional totalizers• mass flowrate return (qmR) + optional totalizers• volumetric flowrate at return (qvR) + optional totalizers• pressure at return (pR)• temperature at return (TR)• density at return (ρR)• enthalpy at return (hR)
--------------------------------	---

5.3.7 Steam – Condensate delta Heat

Steam – Condensate Δ Heat allows to calculate compensated flow and heat for saturated or superheated steam including condensate billing. Flowrates are measured in both, supply (steam) and return (condensate) pipeline. In case of saturated steam operation only one parameter is measured, either temperature or pressure. The second value is calculated based on the build-in saturation curve.

SHORT NAME	Steam-Condensate Δ Heat																																			
FULL NAME	The flows and differential heat in a steam-condensate installation with partial return of condensate																																			
TYPE OF MEDIUM	Power supply: Superheated steam Return: Condensate	Supply: Saturated steam Return: Condensate																																		
ADDITIONAL SETTINGS	-																																			
LAYOUT DIAGRAM	<table border="1" data-bbox="517 987 995 1272"> <thead> <tr> <th colspan="2">Steam open circuit</th> </tr> </thead> <tbody> <tr> <td>A.ΔP</td> <td>137.05 kW</td> </tr> <tr> <td>A.PS</td> <td>816.03 kW</td> </tr> <tr> <td>A.qmS</td> <td>0.28 kg/s</td> </tr> <tr> <td>A.qvS</td> <td>456.76 m³/h</td> </tr> <tr> <td>A.pS</td> <td>500.31 kPaJa</td> </tr> <tr> <td>A.TS</td> <td>229.08 °C</td> </tr> <tr> <td>A.pS</td> <td>2.20 kg/m³</td> </tr> <tr> <td>A.hS</td> <td>2917.45 kJ/kg</td> </tr> <tr> <td>A.ΔT</td> <td>143.82 °C</td> </tr> <tr> <td>A.PR</td> <td>678.97 kW</td> </tr> <tr> <td>A.qmR</td> <td>1.90 kg/s</td> </tr> <tr> <td>A.qvR</td> <td>7.06 m³/h</td> </tr> <tr> <td>A.pR</td> <td>415.41 kPaJa</td> </tr> <tr> <td>A.TR</td> <td>85.25 °C</td> </tr> <tr> <td>A.pR</td> <td>968.59 kg/m³</td> </tr> <tr> <td>A.hR</td> <td>357.29 kJ/kg</td> </tr> </tbody> </table>		Steam open circuit		A. Δ P	137.05 kW	A.PS	816.03 kW	A.qmS	0.28 kg/s	A.qvS	456.76 m ³ /h	A.pS	500.31 kPaJa	A.TS	229.08 °C	A.pS	2.20 kg/m ³	A.hS	2917.45 kJ/kg	A. Δ T	143.82 °C	A.PR	678.97 kW	A.qmR	1.90 kg/s	A.qvR	7.06 m ³ /h	A.pR	415.41 kPaJa	A.TR	85.25 °C	A.pR	968.59 kg/m ³	A.hR	357.29 kJ/kg
Steam open circuit																																				
A. Δ P	137.05 kW																																			
A.PS	816.03 kW																																			
A.qmS	0.28 kg/s																																			
A.qvS	456.76 m ³ /h																																			
A.pS	500.31 kPaJa																																			
A.TS	229.08 °C																																			
A.pS	2.20 kg/m ³																																			
A.hS	2917.45 kJ/kg																																			
A. Δ T	143.82 °C																																			
A.PR	678.97 kW																																			
A.qmR	1.90 kg/s																																			
A.qvR	7.06 m ³ /h																																			
A.pR	415.41 kPaJa																																			
A.TR	85.25 °C																																			
A.pR	968.59 kg/m ³																																			
A.hR	357.29 kJ/kg																																			
INPUT PROCESS VALUES	<ul style="list-style-type: none"> • pressure at supply (pS) • temperature at supply (TS) • mass flowrate at supply (qmS) or volumetric flowrate at supply (qvS) or differential pressure at supply(ΔpS) • pressure at return (pR), • temperature at return (TR), • mass flowrate at return (qmR) or volumetric flowrate at return (qvR) or differential pressure at return (ΔpR) 																																			

COMPUTED PROCESS VALUES	<ul style="list-style-type: none">• heat flowrate difference between supply and return (ΔP) + optional totalizers• temperature difference between supply and return (ΔT)• heat flowrate at supply (PS) + optional totalizers• mass flowrate at supply (qmS) + optional totalizers• volumetric flowrate at supply (qvS) + optional totalizers• pressure at supply (pS)• temperature at supply (TS)• density at supply (ρS)• enthalpy at supply (hS)• heat flowrate at return (PR) + optional totalizers• mass flowrate at return (qmR) + optional totalizers• volumetric flowrate at return (qvR) + optional totalizers• pressure at return (pR)• temperature at return (TR)• density at return (ρR)• enthalpy at return (hR)
--------------------------------	---

5.3.8 Steam generator

Steam generator allows to calculate compensated flow and heat for saturated or superheated steam including supply water billing. Application may use flowrate measurements in supply and return pipeline, as well as only one measurement, either in supply or return pipeline. In case of saturated steam operation only one parameter is measured, either temperature or pressure. The second value is calculated based on the build-in saturation curve.

SHORT NAME	Steam generator																																																																					
FULL NAME	The flow and differential heat in a steam-generating installation with the supplied water flowrate measured																																																																					
TYPE OF MEDIUM	Supply: Water Return: Superheated steam	Supply: Water Return: Saturated steam																																																																				
ADDITIONAL SETTINGS	-																																																																					
LAYOUT DIAGRAM	<table border="1" data-bbox="515 1021 991 1305"> <thead> <tr> <th colspan="2">Steam Generator</th> </tr> </thead> <tbody> <tr> <td>A.ΔP</td> <td>173.76 kW</td> </tr> <tr> <td>A.PS</td> <td>40.66 kW</td> </tr> <tr> <td>A.qmS</td> <td>0.44 kg/s</td> </tr> <tr> <td>A.qvS</td> <td>1.59 m³/h</td> </tr> <tr> <td>A.pS</td> <td>113.15 kPaJa</td> </tr> <tr> <td>A.TS</td> <td>22.04 °C</td> </tr> <tr> <td>A.pR</td> <td>997.75 kg/m³</td> </tr> <tr> <td>A.hS</td> <td>92.57 kJ/kg</td> </tr> <tr> <td>A.ΔT</td> <td>156.91 °C</td> </tr> <tr> <td>A.PR</td> <td>214.42 kW</td> </tr> <tr> <td>A.qmR</td> <td>0.08 kg/s</td> </tr> <tr> <td>A.qvR</td> <td>151.49 m³/h</td> </tr> <tr> <td>A.pR</td> <td>368.26 kPaJa</td> </tr> <tr> <td>A.TR</td> <td>178.95 °C</td> </tr> <tr> <td>A.pR</td> <td>1.81 kg/m³</td> </tr> <tr> <td>A.hR</td> <td>2818.33 kJ/kg</td> </tr> </tbody> </table> <table border="1" data-bbox="1029 1021 1505 1305"> <thead> <tr> <th colspan="2">Steam Generator</th> </tr> </thead> <tbody> <tr> <td>A.ΔP</td> <td>548.14 kW</td> </tr> <tr> <td>A.PS</td> <td>40.68 kW</td> </tr> <tr> <td>A.qmS</td> <td>0.44 kg/s</td> </tr> <tr> <td>A.qvS</td> <td>1.59 m³/h</td> </tr> <tr> <td>A.pS</td> <td>113.06 kPaJa</td> </tr> <tr> <td>A.TS</td> <td>22.07 °C</td> </tr> <tr> <td>A.pR</td> <td>997.74 kg/m³</td> </tr> <tr> <td>A.hS</td> <td>92.67 kJ/kg</td> </tr> <tr> <td>A.ΔT</td> <td>156.90 °C</td> </tr> <tr> <td>A.PR</td> <td>588.82 kW</td> </tr> <tr> <td>A.qmR</td> <td>0.21 kg/s</td> </tr> <tr> <td>A.qvR</td> <td>151.38 m³/h</td> </tr> <tr> <td>A.pR</td> <td>979.31 kPaJa</td> </tr> <tr> <td>A.TR</td> <td>178.97 °C</td> </tr> <tr> <td>A.pR</td> <td>5.04 kg/m³</td> </tr> <tr> <td>A.hR</td> <td>2776.34 kJ/kg</td> </tr> </tbody> </table>		Steam Generator		A.ΔP	173.76 kW	A.PS	40.66 kW	A.qmS	0.44 kg/s	A.qvS	1.59 m³/h	A.pS	113.15 kPaJa	A.TS	22.04 °C	A.pR	997.75 kg/m³	A.hS	92.57 kJ/kg	A.ΔT	156.91 °C	A.PR	214.42 kW	A.qmR	0.08 kg/s	A.qvR	151.49 m³/h	A.pR	368.26 kPaJa	A.TR	178.95 °C	A.pR	1.81 kg/m³	A.hR	2818.33 kJ/kg	Steam Generator		A.ΔP	548.14 kW	A.PS	40.68 kW	A.qmS	0.44 kg/s	A.qvS	1.59 m³/h	A.pS	113.06 kPaJa	A.TS	22.07 °C	A.pR	997.74 kg/m³	A.hS	92.67 kJ/kg	A.ΔT	156.90 °C	A.PR	588.82 kW	A.qmR	0.21 kg/s	A.qvR	151.38 m³/h	A.pR	979.31 kPaJa	A.TR	178.97 °C	A.pR	5.04 kg/m³	A.hR	2776.34 kJ/kg
Steam Generator																																																																						
A.ΔP	173.76 kW																																																																					
A.PS	40.66 kW																																																																					
A.qmS	0.44 kg/s																																																																					
A.qvS	1.59 m³/h																																																																					
A.pS	113.15 kPaJa																																																																					
A.TS	22.04 °C																																																																					
A.pR	997.75 kg/m³																																																																					
A.hS	92.57 kJ/kg																																																																					
A.ΔT	156.91 °C																																																																					
A.PR	214.42 kW																																																																					
A.qmR	0.08 kg/s																																																																					
A.qvR	151.49 m³/h																																																																					
A.pR	368.26 kPaJa																																																																					
A.TR	178.95 °C																																																																					
A.pR	1.81 kg/m³																																																																					
A.hR	2818.33 kJ/kg																																																																					
Steam Generator																																																																						
A.ΔP	548.14 kW																																																																					
A.PS	40.68 kW																																																																					
A.qmS	0.44 kg/s																																																																					
A.qvS	1.59 m³/h																																																																					
A.pS	113.06 kPaJa																																																																					
A.TS	22.07 °C																																																																					
A.pR	997.74 kg/m³																																																																					
A.hS	92.67 kJ/kg																																																																					
A.ΔT	156.90 °C																																																																					
A.PR	588.82 kW																																																																					
A.qmR	0.21 kg/s																																																																					
A.qvR	151.38 m³/h																																																																					
A.pR	979.31 kPaJa																																																																					
A.TR	178.97 °C																																																																					
A.pR	5.04 kg/m³																																																																					
A.hR	2776.34 kJ/kg																																																																					
INPUT PROCESS VALUES	<ul style="list-style-type: none"> pressure at supply (pS) temperature at supply (TS) mass flowrate at supply (qmS) or volumetric flowrate at supply (qvS) or differential pressure at supply (ΔpS) pressure at return (pR) temperature at return (TR) mass flow rate at return (qmR) or volumetric flowrate at return (qvR) or differential pressure at return (ΔpR) 																																																																					
COMPUTED PROCESS VALUES	<ul style="list-style-type: none"> heat flowrate difference between supply and return difference (ΔP) + optional totalizers temperature difference between supply and return (ΔT) heat flowrate at supply (PS) + optional totalizers mass flowrate at supply (qmS) + optional totalizers 																																																																					

**COMPUTED PROCESS
VALUES**

- volumetric flowrate at supply (qvS) + optional totalizers
- pressure at supply (pS)temperature at supply (TS)
- density at supply (ρS)
- enthalpy at supply (hS)
- heat flowrate at return (PR) + optional totalizers
- mass flowrate at return (qmR) + optional totalizers
- volumetric flowrate at return (qvR) + optional totalizers
- pressure at return (pR)
- temperature at return (TR)
- density at return (ρR)
- enthalpy at return (hR)

5.3.9 Gas Flow

Gas flow allows to calculate compensated flow according to pressure and/or temperature measurements. The ideal gas equation is used for the calculations, taking into account the compressibility factor (Z-factor). Instead of ideal gas equation user may define own table with density depending on temperature and pressure. The application is mainly suitable for technical gases.

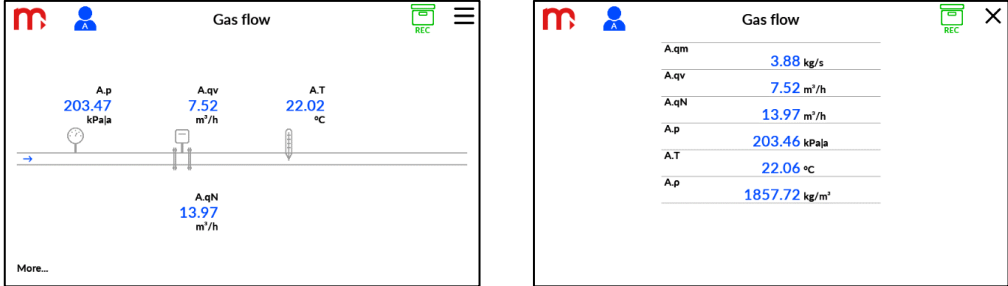
SHORT NAME	Gas flow
FULL NAME	The flow of a gas measurement
TYPE OF MEDIUM	Gas / Technical gas
ADDITIONAL SETTINGS	-
LAYOUT DIAGRAM	
INPUT PROCESS VALUES	<ul style="list-style-type: none"> • pressure (p) • temperature (T) • mass flowrate (qm) or volumetric flowrate (qv) or differential pressure (Δp) or gas volume flowrate in standard units (qN)
COMPUTED PROCESS VALUES	<ul style="list-style-type: none"> • mass flowrate (qm) + optional totalizers • volumetric flowrate (qv) + optional totalizers • gas volume flowrate (qN) + optional totalizers • pressure (p) • temperature (T) • density (ρ)

5.3.10 Gas Heat

Gas flow allows to calculate compensated flow and heat according to pressure and/or temperature measurements. The ideal gas equation is used for the calculations, taking into account the compressibility factor (Z-factor). Instead of ideal gas equation user may define own table with density depending on temperature and pressure. Enthalpy always have to be entered as a user medium table. The application may also be used to calculate combustion heat. Then calorific of the gas have to be entered instead of enthalpy.

SHORT NAME	Gas heat
FULL NAME	The gas flow and heat measurement
TYPE OF MEDIUM	Gas
ADDITIONAL SETTINGS	-
LAYOUT DIAGRAM	
INPUT PROCESS VALUES	<ul style="list-style-type: none"> • pressure (p) • temperature (T) • mass flowrate (qm) or volumetric flowrate (qv) or differential pressure (Δp) or gas volume flowrate in standard units
COMPUTED PROCESS VALUES	<ul style="list-style-type: none"> • heat flowrate (P) + optional totalizers • mass flowrate (qm) + optional totalizers • volumetric flowrate (qv) + optional totalizers • gas volume flowrate (qN) + optional totalizers • pressure (p) • temperature (T) • density (ρ)

5.4 Summary of process values used in different types of applications

Below is a table showing process values measured and calculated depending on the type of application. The table contains information for water and steam. If a user characteristic is used, some values may not be calculated in the application.

- + process values always calculated.
- process values calculated when orifice type flowmeter is used.
- * process values or totalizers calculated if configured (may not be calculated).

		Type of measuring application										
		Liquid Flow	Liquid Heat	Liquid delta Heat (closed loop)	Liquid delta Heat	Steam net Heat	Steam – Cond. delta Heat (closed loop)	Steam – Cond. delta Heat	Steam generat or	Gas Flow	Gas Heat	
Measuring application A and B	A.ΔP B.ΔP	PV			+	+		+	+	+		
		Min			+	+		+	+	+		
		Max			+	+		+	+	+		
		Σ1			*	*		*	*	*		
		Σ2			*	*		*	*	*		
	A.ΔT B.ΔT	PV			+	+		+	+	+		
		Min			+	+		+	+	+		
		Max			+	+		+	+	+		
		Σ1										
		Σ2										
	A.P A.PS B.P B.PS	PV		+	+	+	+	+	+	+		+
		Min		+	+	+	+	+	+	+		+
		Max		+	+	+	+	+	+	+		+
		Σ1			*	*	*	*	*	*		*
		Σ2			*	*	*	*	*	*		*
	A.qm A.qmS B.qm B.qmS	PV	+	+	+	+	+	+	+	+	+	+
		Min	+	+	+	+	+	+	+	+	+	+
		Max	+	+	+	+	+	+	+	+	+	+
		Σ1	*	*	*	*	*	*	*	*	*	*
		Σ2	*	*	*	*	*	*	*	*	*	*
	A.qv A.qvS B.qv B.qvS	PV	+	+	+	+	+	+	+	+	+	+
		Min	+	+	+	+	+	+	+	+	+	+
		Max	+	+	+	+	+	+	+	+	+	+
		Σ1	*	*	*	*	*	*	*	*	*	*
		Σ2	*	*	*	*	*	*	*	*	*	*
	A.qN A.qNS B.qN B.qNS	PV									+	+
		Min									+	+
		Max									+	+
Σ1										*	*	
Σ2										*	*	
A.p A.pS B.p B.pS	PV	+	+	+	+	+	+	+	+	+	+	
	Min	+	+	+	+	+	+	+	+	+	+	
	Max	+	+	+	+	+	+	+	+	+	+	
	Σ1											
	Σ2											
A.T A.TS B.T B.TS	PV	+	+	+	+	+	+	+	+	+	+	
	Min	+	+	+	+	+	+	+	+	+	+	
	Max	+	+	+	+	+	+	+	+	+	+	
	Σ1											
	Σ2											
A.ρ A.ρS B.ρ B.ρS	PV	+	+	+	+	+	+	+	+	+	+	
	Min	+	+	+	+	+	+	+	+	+	+	
	Max	+	+	+	+	+	+	+	+	+	+	
	Σ1											
	Σ2											

		Type of measuring application										
		Liquid Flow	Liquid Heat	Liquid delta Heat (closed loop)	Liquid delta Heat	Steam net Heat	Steam - Cond. delta Heat (closed loop)	Steam - Cond. delta Heat	Steam generator	Gas Flow	Gas Heat	
Measuring application A and B	A.h A.hS B.h B.hS	PV		+	+	+	+	+	+	+		+
		Min		+	+	+	+	+	+	+		+
		Max		+	+	+	+	+	+	+		+
		Σ1										
		Σ2										
	A.Δp A.ΔpS B.Δp B.ΔpS	PV	•	•	•	•	•	•	•	•	•	•
		Min	•	•	•	•	•	•	•	•	•	•
		Max	•	•	•	•	•	•	•	•	•	•
		Σ1										
		Σ2										
	A.PR B.PR	PV			+	+		+	+	+		
		Min			+	+		+	+	+		
		Max			+	+		+	+	+		
		Σ1			*	*		*	*	*		
		Σ2			*	*		*	*	*		
	A.qmR B.qmR	PV			+	+		+	+	+		
		Min			+	+		+	+	+		
		Max			+	+		+	+	+		
		Σ1			*	*		*	*	*		
		Σ2			*	*		*	*	*		
	A.qvR B.qvR	PV			+	+		+	+	+		
		Min			+	+		+	+	+		
		Max			+	+		+	+	+		
		Σ1			*	*		*	*	*		
		Σ2			*	*		*	*	*		
	A.qNR B.qNR	PV										
		Min										
		Max										
		Σ1										
		Σ2										
	A.pR B.pR	PV			+	+		+	+	+		
		Min			+	+		+	+	+		
		Max			+	+		+	+	+		
		Σ1										
		Σ2										
	A.TR B.TR	PV			+	+		+	+	+		
		Min			+	+		+	+	+		
		Max			+	+		+	+	+		
		Σ1										
		Σ2										
A.pR B.pR	PV			+	+		+	+	+			
	Min			+	+		+	+	+			
	Max			+	+		+	+	+			
	Σ1											
	Σ2											
A.hR B.hR	PV			+	+		+	+	+			
	Min			+	+		+	+	+			
	Max			+	+		+	+	+			
	Σ1											
	Σ2											
A.ΔpR B.ΔpR	PV			•	•		•	•	•			
	Min			•	•		•	•	•			
	Max			•	•		•	•	•			
	Σ1											
	Σ2											

5.5 Hierarchy of process values calculations and failure indication.

When all measurements and calculations are correct, then all process values digits are displayed in blue. Exception is intended change of result colour to red, green or orange, when alarm threshold is activated.

When error occurs or value cannot be figured, the result is exchanged by error symbol as listed below:

-----	(7x '-') Channel off, the symbol is displayed in User Trends Screens and User Table Screens. For a disabled channel, the Single Result Window is not displayed. The symbol is displayed for the disabled input.
-----	(5x '-') When the value is over range, is less than -99999999999999 or greater than 999999999999999.
---	(3x '-') Symbol used in the archive files for a disabled channel archived.
---W---	Wait, the process value is not ready. The symbol is displayed if the channel is connected to an input that has not been configured yet or is trying to connect to the remote sensor. The symbol is displayed in particular at the beginning of the device's operation.
--- ---	The current loop 4-20mA below 3.6 mA (break) or RTD sensor failure.
---E---	The current loop error (> 22 mA).
---R---	Sensor value out of measuring range or failure.
--ERR--	Measurement error for a reason other than those listed above.

When input detects failure (e.g. break in 4-20 mA loop), then failure value may be used instead of measurement. The value is displayed in black digits on yellow background to inform on failure status. But this failure value may be used for farther calculations. In such case as a consequence all results are displayed in black digits instead of blue. (Use of failure value have to be declared and value entered in settings for the input.) In this way the calculated process values inherits status from source value

Note:

In RTD 4-wire connection not all break wire failures are detected by the device.

5.6 Process engineering units

5.6.1 Process values

The device has defined list of engineering units available by default for process values. In special cases, it is possible to add user defined units. More information in the chapter [User unit](#).

Pressure values can be displayed in absolute units (with suffix "|a" or without any suffix) or in gauge units (suffix "|g"), Gauge unit is calculated above barometric pressure entered as a constant value. The value of barometric pressure may be changed in the [measurement system settings](#) window.

Attention should be paid to choose the correct time base for flowrate units. The time base determines flowrate calculations and totalizers calculations.

In the table below there are engineering units used in flow computer. (Description of the channels symbols are explained in the chapter [Channel symbols in application A and B](#).)

Channel symbol		Defined units						
APPLICATION A/B	A.ΔP B.ΔP	W	kW	MW	GW	Btu/s	kBtu/s	cal/s
		kcal/s	kJ/h	MJ/h	GJ/h	Btu/h	kBtu/h	MBtu/h
		cal/h	kcal/h	J/min	kJ/min	MJ/min	GJ/min	Btu/min
		kBtu/min	MBtu/min	cal/min	kcal/min	Mcal/min		
	A.ΔT B.ΔT	°C	K	°F	°R			
	A.P A.PS B.P B.PS	W	kW	MW	GW	Btu/s	kBtu/s	cal/s
		kcal/s	kJ/h	MJ/h	GJ/h	Btu/h	kBtu/h	MBtu/h
		cal/h	kcal/h	J/min	kJ/min	MJ/min	GJ/min	Btu/min
		kBtu/min	MBtu/min	cal/min	kcal/min	Mcal/min		
	A.qm A.qmS B.qm B.qmS	g/s	kg/s	kg/h	t/h	g/min	kg/min	t/min
		lb/s	lb/min	ton/min	lb/h	ton/h		
A.qv A.qvS B.qv B.qvS	cm ³ /s	dm ³ /s	m ³ /s	l/s	in ³ /s	ft ³ /s	gal/s	
	dbbl/s	cm ³ /min	dm ³ /min	m ³ /min	l/min	in ³ /min	ft ³ /min	
	gal/min	dbbl/min	cm ³ /h	dm ³ /h	m ³ /h	l/h	in ³ /h	
	ft ³ /h	gal/h	dbbl/h	Ndm ³ /s	Nm ³ /s	NI/s	scf/s	
	mcf/s	Ndm ³ /min	Nm ³ /min	NI/min	scf/min	mcf/min	Ndm ³ /h	
	Nm ³ /h	NI/h	scf/min	mcf/min				
A.qN A.qNS B.qN B.qNS	cm ³ /s	dm ³ /s	m ³ /s	l/s	in ³ /s	ft ³ /s	gal/s	
	dbbl/s	cm ³ /min	dm ³ /min	m ³ /min	l/min	in ³ /min	ft ³ /min	
	gal/min	dbbl/min	cm ³ /h	dm ³ /h	m ³ /h	l/h	in ³ /h	
	ft ³ /h	gal/h	dbbl/h	Ndm ³ /s	Nm ³ /s	NI/s	scf/s	
	mcf/s	Ndm ³ /min	Nm ³ /min	NI/min	scf/min	mcf/min	Ndm ³ /h	
	Nm ³ /h	NI/h	scf/min	mcf/min				
A.p A.pS B.p B.pS	kPa a	MPa a	bar a	ksc a	psi a	Torr a	atm a	
	kPa g	MPa g	bar g	ksc g	psi g	Torr g	atm g	
	Pa	kPa	MPa	mbar	bar	ksc	inAq	
	psi	Torr	atm					
A.T/A.TS B.T/B.TS	°C	K	°F	°R				



APPLICATION A/B	A.ρ A.ρS B.ρ B.ρS	kg/m ³	g/cm ³	lb/ft ³				
	A.h A.hS B.h B.hS	kJ/kg	Btu/lg					
	A.Δp A.ΔpS B.Δp B.ΔpS	kPa a	MPa a	bar a	ksc a	psi a	Torr a	atm a
		Pa	kPa	MPa	mbar	bar	ksc	inAq
		psi	Torr					
	A.PR B.PR	W	kW	MW	GW	Btu/s	kBtu/s	cal/s
		kcal/s	kJ/h	MJ/h	GJ/h	Btu/h	kBtu/h	MBtu/h
		cal/h	kcal/h	J/min	kJ/min	MJ/min	GJ/min	Btu/min
		kBtu/min	MBtu/min	cal/min	kcal/min	Mcal/min		
	A.qmR B.qmR	g/s	kg/s	kg/h	t/h	g/min	kg/min	t/min
		lb/s	lb/min	ton/min	lb/h	ton/h		
	A.qvR B.qvR	cm ³ /s	dm ³ /s	m ³ /s	l/s	in ³ /s	ft ³ /s	gal/s
		dbbl/s	cm ³ /min	dm ³ /min	m ³ /min	l/min	in ³ /min	ft ³ /min
gal/min		dbbl/min	cm ³ /h	dm ³ /h	m ³ /h	l/h	in ³ /h	
ft ³ /h		gal/h	dbbl/h	Ndm ³ /s	Nm ³ /s	NI/s	scf/s	
mcf/s		Ndm ³ /min	Nm ³ /min	NI/min	scf/min	mcf/min	Ndm ³ /h	
Nm ³ /h		NI/h	scf/min	mcf/min				
A.qNR B.qNR	cm ³ /s	dm ³ /s	m ³ /s	l/s	in ³ /s	ft ³ /s	gal/s	
	dbbl/s	cm ³ /min	dm ³ /min	m ³ /min	l/min	in ³ /min	ft ³ /min	
	gal/min	dbbl/min	cm ³ /h	dm ³ /h	m ³ /h	l/h	in ³ /h	
	ft ³ /h	gal/h	dbbl/h	Ndm ³ /s	Nm ³ /s	NI/s	scf/s	
	mcf/s	Ndm ³ /min	Nm ³ /min	NI/min	scf/min	mcf/min	Ndm ³ /h	
	Nm ³ /h	NI/h	scf/min	mcf/min				
A.pR B.pR	kPa a	MPa a	bar a	ksc a	psi a	Torr a	atm a	
	kPa g	MPa g	bar g	ksc g	psi g	Torr g	atm g	
	Pa	kPa	MPa	mbar	bar	ksc	inAq	
	psi	Torr	atm					

APPLICATION A/B	A.TR B.TR	°C	K	°F	°R			
	A.ρR B.ρR	kg/m ³	g/cm ³	lb/ft ³				
	A.hR B.hR	kJ/kg	Btu/lg					
	A.ΔpR B.ΔpR	kPa a Pa psi	MPa a kPa Torr	bar a MPa	ksc a mbar	psi a bar	Torr a ksc	atm a inAq

For channels in the X application, it is possible to freely choose the unit from all the available units (table below). It is also possible to configure channel without specifying the unit. It is possible to define user engineering unit, if required. More information in the chapter [User unit](#).

	Channel symbol	Defined units						
APPLICATION X	X.01 .. X.24	W	kW	MW	GW	Btu/s	kBtu/s	cal/s
		kcal/s	kJ/h	MJ/h	GJ/h	Btu/h	kBtu/h	MBtu/h
		cal/h	kcal/h	J/min	kJ/min	MJ/min	GJ/min	Btu/min
		kBtu/min	MBtu/min	cal/min	kcal/min	Mcal/min	kJ	MJ
		GJ	kWh	MWh	Btu	kBtu	MBtu	kcal
		Mcal	Gcal	g/s	kg/s	kg/h	t/h	g/min
		kg/min	t/min	lb/s	lb/min	ton/min	lb/h	ton/h
		g	kg	t	lb	ton	cm ³ /s	dm ³ /s
		m ³ /s	l/s	in ³ /s	ft ³ /s	gal/s	dbbl/s	cm ³ /min
		dm ³ /min	m ³ /min	l/min	in ³ /min	ft ³ /min	gal/min	dbbl/min
		cm ³ /h	dm ³ /h	m ³ /h	l/h	in ³ /h	ft ³ /h	gal/h
		dbbl/h	cm ³	dm ³	m ³	l	in ³	ft ³
		gal	dbbl	Ndm ³ /s	Nm ³ /s	NI/s	scf/s	mcf/s
		Ndm ³ /min	Nm ³ /min	NI/min	scf/min	mcf/min	Ndm ³ /h	Nm ³ /h
		NI/h	scf/min	mcf/min	Ndm ³	Nm ³	NI	scf
		mcf	kPa a	MPa a	bar a	ksc a	psi a	Torr a
		atm a	kPa g	MPa g	bar g	ksc g	psi g	Torr g
		atm g	Pa	kPa	MPa	mbar	bar	ksc
		inAq	Psi	Torr	atm	°C	K	°F
		°R	kJ/kg	Btu/lb	kg/m ³	g/cm ³	lb/ft ³	m ³ /kg
ft ³ /lb	Mm	in	ppm/K	ppm/°F	kJ/kg K			

5.6.2 Totalizers

The units listed below are available by default for totalizers. If required, it is also possible to add a user unit (for more information, see [User unit](#)).

		Defined units						
Channel symbol								
Σ1/Σ2 APPLICATION A/B	A.ΔP	kJ	MJ	GJ	kWh	MWh	Btu	kBtu
	B.ΔP	MBtu	kcal	Mcal	Gcal			
	A.P/A.PS	kJ	MJ	GJ	kWh	MWh	Btu	kBtu
	B.P/B.PS	MBtu	kcal	Mcal	Gcal			
	A.qm	g	kg	t	lb	ton		
	A.qmS							
	B.qm							
	B.qmS							
	A.qv	cm ³	dm ³	m ³	l	in ³	ft ³	gal
	A.qvS	dbbl	Ndm ³	Nm ³	NI	scf	mcf	
	B.qv							
	B.qvS							
A.qN	cm ³	dm ³	m ³	l	in ³	ft ³	gal	
A.qNS	dbbl	Ndm ³	Nm ³	NI	scf	mcf		
B.qN								
B.qNS								
A.PR	kJ	MJ	GJ	kWh	MWh	Btu	kBtu	
B.PR	MBtu	kcal	Mcal	Gcal				
A.qmR	g	kg	t	lb	ton			
B.qmR								
A.qvR	cm ³	dm ³	m ³	l	in ³	ft ³	gal	
B.qvR	dbbl	Ndm ³	Nm ³	NI	scf	mcf		
A.qNR	cm ³	dm ³	m ³	l	in ³	ft ³	gal	
B.qNR	dbbl	Ndm ³	Nm ³	NI	scf	mcf		

For channels in the X application, it is possible to freely choose the unit from the available list. It is also possible to configure totalizer without specifying a unit or define user unit (for more information, see in the chapter [User unit](#)).

Channel symbol		Defined units						
Σ1/Σ2 APPLICATION X	X.01 .. X.24	kJ	MJ	GJ	kWh	MWh	Btu	kBtu
		MBtu	kcal	Mcal	Gcal	g	kg	t
		lb	ton	cm ³	dm ³	m ³	l	in ³
		ft ³	gal	dbbl	Ndm ³	Nm ³	NI	scf
		mcf	kPa a	MPa a	bar a	ksc a	psi a	Torr a
		atm a	kPa g	MPa g	bar g	ksc g	psi g	Torr g
		atm g	Pa	kPa	MPa	mbar	bar	ksc
		inAq	psi	Torr	atm	°C	K	°F
		°R	kJ/kg	Btu/lb	kg/m ³	g/cm ³	lb/ft ³	m ³ /kg
		ft ³ /lb	mm	in	ppm/K	ppm/°F	kJ/kg K	

6 ARCHIVE

Device has advanced data recording functions. There are two types of archive: process data (data, totalizers, events) and service (service log, settings log). Process data archive is configured and controlled by the user, service archive is updated automatically. All data is archived in internal non-volatile memory in file form.

Data archive and Totalizers archive need to be configured. The settings need two steps, general settings (chapter [Archive settings](#)) and assigning channels to be archived (chapter [Channels settings](#)).

Data archive records are saved with two possible frequencies, every: 1 s, 2 s, 5 s, 10 s, 15 s, 30 s, 1 min, 5 min, 10 min, 15 min, 30 min, 1 h, 2 h, 4 h or 12 h, according to the settings. Switching the frequency is controlled by alarm(s). The records in the Totalizers archive are saved every 1 min, 5 min, 10 min, 15 min, 30 min, 1 h, 2 h, 4 h, 12 h or 24 h, according to the settings (for more information I chapter [Archive settings](#)).

The record in the Events archive is saved when an event occurs (e.g. power on/off, alarm exceeded, device parameters change, user log in / log out). Some events can be configured during device setup.

6.1 Archive file types

The device saves three types of archive files:

- Data archive (file name: *YYADXX_yymmdd.csv*)
- Totalizers archive (file name: *YYATXX_yymmdd.csv*)
- Event archive (file name: *YYAEXX_yymmdd.csv*)

YY - Device ID, value consistent with user settings,

XX - Archive file number, numbering starts with 01 and ends with 99. If 99 is exceeded, the numbering starts again to 01.

yymmdd - date of archive file creation.

Each archive is saved in csv format. File modification date indicates the latest saved record.

Service archive files and settings archive files are available in settings menu and have auxiliary meaning from the user point of operation.

Note:

If available memory space is less than 5%, the oldest files are automatically deleted until minimum of 10% free space accessed. Even thou the memory space is 2 GB and is big enough to store quite large amount of archive data, it is recommended to copy archive files and delete old files periodically.

6.2 Creating new archive files

New archive files (data, totalizers, events) are created automatically or by user. At least one process value or totalizer must be declared for archiving to create new archive files by user. Event archive file is always created when condition for new archive files occurs. A new archive files is created in the following cases:

- by tapping New Archive button on the archive screen (at least User log in is required)
- automatically, when archive mode configured as 'daily', 'weekly' or 'monthly' when time condition occurs
- automatically, when changing and saving new settings (only setting having consequence for archiving)

6.3 Start, resume, and stop archiving

The Archive is controlled in Archive window. It is available from drop-down Main Menu or by tapping the icon  on the title bar. Using the function button START/STOP it is possible to start, resume or stop the archiving process.

Note:

When new archive file is created, the archiving is not started automatically. It is required to start archiving as separate operation.

Archive control functions require at least User logged in.

6.4 View archive files on the device screen

Process data archived in the device memory may be scrolled back on the device front screen in *Archive* menu by tapping *View archive*. At one time it is possible view up to six selected process values.

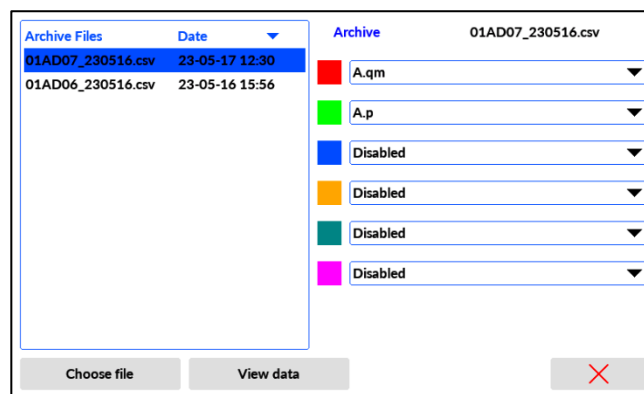

Data is presented as a trend lines with digital value pointed by the cursor. All trends are scaled 0 to 100% according to range entered for every channel in Channels setting. The range may be verified tapping *Legend* button.

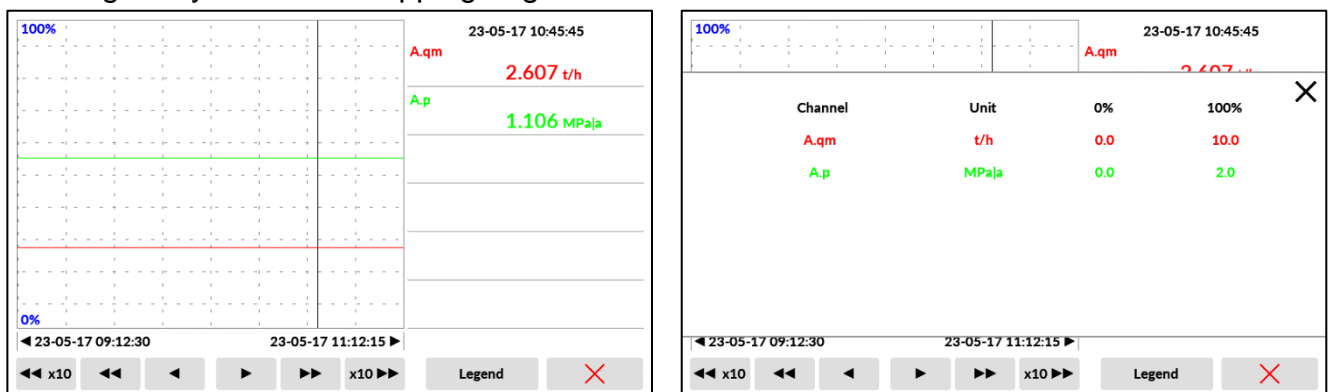

Note:

Only process data may be scrolled back. Totalizers are not available to browse on the device screen. More detailed data analysis including totalizers may be done in the PC computer using *Report* software. (More details in chapter [Supporting Software](#).)

6.5 Copy archive files from the device

Copying archive files using the USB port is available in *USB* window accessed either from *Archive* window or *settings main menu* tapping USB icon. (More details in chapter [Write and read files via USB port.](#))

Archive files may also be copied using the device's web server. The device have to be connected to LAN using build in Ethernet port. More information in the chapter [Web Server.](#)

6.6 Archive file organization

All archive files are saved in CSV format. Values are separated with comma, and as a digital separator is decimal point. This universal format allows to open file with simple text editor, spreadsheet or *Report* software. Every file is protected by encrypted CRC byte to protect against intentional or not intentional file modification. *Report* software can verify file and report such modifications.

Note:

In some local settings may be required to undertake extra action, like e.g. converting digital separator instead of point to comma.

Each archive file has a header containing:

DEVICE MODEL	device model, for this device it is FP40
FW VERSION	firmware version in which the archive was created, firmware update always results in creation of a new archive file
S/N	device serial number
ID	device ID
HEADER ROW COUNTER	information about the number of rows in the header
ARCHIVE TYPE	archive type: DATA (data archive), EVENT (event archive), TOT (totalizers archive)
CRC1	encrypted CRC control value

Data and totalizers archive files have an additional header containing information about the set of parameters (selected channels, description, unit, etc.).

6.6.1 Data archive

Data archive has additional header following the main header with settings information containing:

SYMBOL	channel symbol
DESCRIPTION	channel description
UNIT	channel assigned unit
INPUT TYPE	measurement input type assigned to the channel: ME (measurement), CO (user formula internal channel, constant value), RE (remote, Modbus TCP)
INPUT NO	input specification - slot numumber and input number e.g. A1 or -- (no physical input, e.g. disabled or calculated))
TREND MIN	trend chart range of Y axis, minimum value
TREND MAX	trend chart range of Y axis, maximum value

Data record has format:

DATE	date stamp in format yy-mm-dd
TIME	time stamp in the format hh:mm:ss
DST	Daylight Saving Time marker (1 – summer, 0 - winter)
CHANNEL VALUE	channel value (header contains channel symbol
CRC2	encrypted CRC control value

6.6.2 Totalizers archive

Totalizers archive has additional header following the main header with settings information containing:

SYMBOL	channel symbol
DESCRIPTION	channel description
TOT1 TYPE TOT2 TYPE	totalizer type: ' ' – off; 1 – Unresattable; 2 – Rasattable; 3 – Daily; 4 – Weekly; '5' – Monthly
TOT1 UNIT TOT2 UNIT	Unit assigned to the totalizer

Totalizers record has format:

DATE	date stamp in format yy-mm-dd
TIME	time stamp in the format hh:mm:ss
DST	Daylight Saving Time marker (1 – summer, 0 - winter)
TOTALIZER VALUE	totalizer value (header contains channel symbol plus totalizer number
CRC2	encrypted CRC control value

Note:

Each totalizer is declared separately for archiving.

6.6.3 Events archive

Events archive has additional header following the main header with settings information containing:

DATE	date stamp in format yy-mm-dd
TIME	time stamp in the format hh:mm:ss
DST	Daylight Saving Time marker (1 – summer, 0 - winter)
EVENT CODE	event code (more information below)
CRC2	encrypted CRC control value

The events codes meaning:

SYS:START	power on
SYS:STOP	power off
SYS:LOGIN: xxxxx	user log in (xxxxx – User / Admin / Servis / Factory
SYS:LOGOUT	user log out
SYS:NEW PARAMETERS	new settings have been saved
SYS:TIME CHANGED	RTC time has been changed
SYS:DATE CHANGED	RTC date has been changed
SYS:CHANNELx: AUXILIARY VALUES RESET	reset of auxiliary values (min, max, totalizer(s)) for selected channel (x – channel symbol)

SYS:APPLICATIONx: AUXILIARY VALUES RESET	reset of auxiliary values (min, max, totalizer(s)) for selected application (x – application A, B or X)
SYS: ALL CHANNELS: AUX VALUES RESET	reset of auxiliary values (min, max, totalizer(s)) for all channel
SYS:xxx ERROR ON	input failure detected (xxx – IN3 .. IN10)
SYS:xxx ERROR OFF	input failure cancelled (xxx – IN3 .. IN10)
SYS:REMOTE INPUTS ERROR ON	remote input (ModbusTCP) failure detected (one or more, no address specification)
REMOTE INPUTS: ERROR OFF	remote input (ModbusTCP) failure cancelled
SYS:RESET	User triggered device restart (menu <i>Settings > General > Service > Restart</i>)
ARCH:NEW	new archive file has been created
ARCH:START	start of data archiving
ARCH:STOP	stop of data archiving
AL:ACK	alarm(s) has been acknowledged
AL:x ALy ON	alarm has been activated (x - channel symbol, y - alarm I or II)
AL:x ALy OFF	alarm has returned to non-active state (x - channel symbol, y - alarm I or II)
EMAIL:OK	e-mail message has been sent
EMAIL:ERROR	e-mail message sent attempt not succeeded

6.6.4 Settings Archive

Every change of settings parameters is saved as a backup copy file in internal flash memory. The list of settings files is available for admin or service. The file name contains date and time in its name: *yymmdd_hhmmss_bkFP40.par*. It is possible to copy selected file to external flash drive and open the file in dedicated software or loaded to device in USB window. (More information in [Supporting Software](#) chapter.)

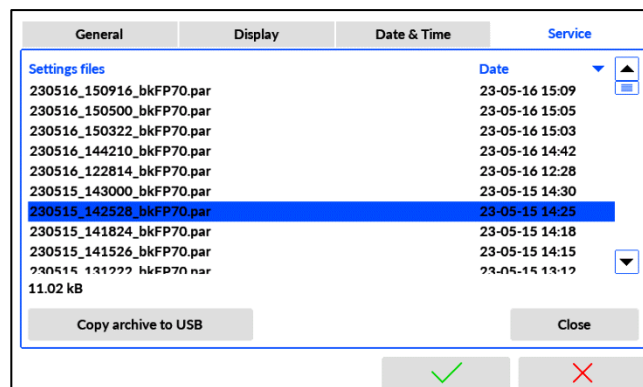

Note:

The list of backup files allows also to verify and control the previous changes in device configuration.

6.6.5 Service Archive

The service archive contains event codes with authorized services. The archive is accessed in *Settings* menu in *Generals* for Admin or Service and may be browsed on the device display or copied to the *authorized.csv* file. The header differs from the other archive files and contains:

DEVICE MODEL	device model, for this device it is FP40
FW VERSION	firmware version in which the archive was created, firmware update always results in creation of a new archive file
S/N	device serial number
MAC ADDR	MAC address
HEADER ROW COUNTER	information about the number of rows in the header
ARCHIVE TYPE	archive type: SERVICE
CRC1	encrypted CRC control value

Service file record has format:

DATE	date stamp in format yy-mm-dd
TIME	time stamp in the format hh:mm:ss
DST	Daylight Saving Time marker (1 – summer, 0 - winter)
CODE	service event code (more information below)
CRC2	encrypted CRC control value

The service events codes meaning:

1	power off
2	power on
3	device restart triggered by the user
4	new settings have been saved
5	settings have been restored to factory default
6	RTC date has been changed
7	RTC time has been changed
8	RTD type input(s) has been calibrated (IN3, IN4)
9	current loop type input(s) has been calibrated (IN4, .. IN10)
10	new value of totalizer(s) has been set
11	archive stopped due to error
12	device restart due to Watchdog timer
13	new firmware for the measuring processor has been uploaded
14	new device firmware has been uploaded
19	automatic archive flash memory clean up
20	automatic archive flash memory clean up error has been detected

7 WEB SERVER

To display web server, device should be configured according to the LAN in which it will work. To connect to device's web server, user have to enter the IP address of the device. in his web browser. The device's web server allows:

- to remote download of archive files
- to view process values in applications A, B
- to view auxiliary values in application X

The web server is designed for check of process data or uploading archive files rather than for continuous monitoring. It will automatically logout after five minutes of inactivity. (This timeout does not apply to process data monitoring in application A, B, X.)

Note:

Correct configuration may require IT service help or consultation on local LAN operation limits.

7.1 Logging in to the web server

After entering the IP address in the web browser, the login window appears. The required password is the device User password. If the User password is deactivated, the log in window is not displayed and there is no password required. When the password is active, then only one user may be logged in. When password is deactivated, then more users may use the web server at the same time.

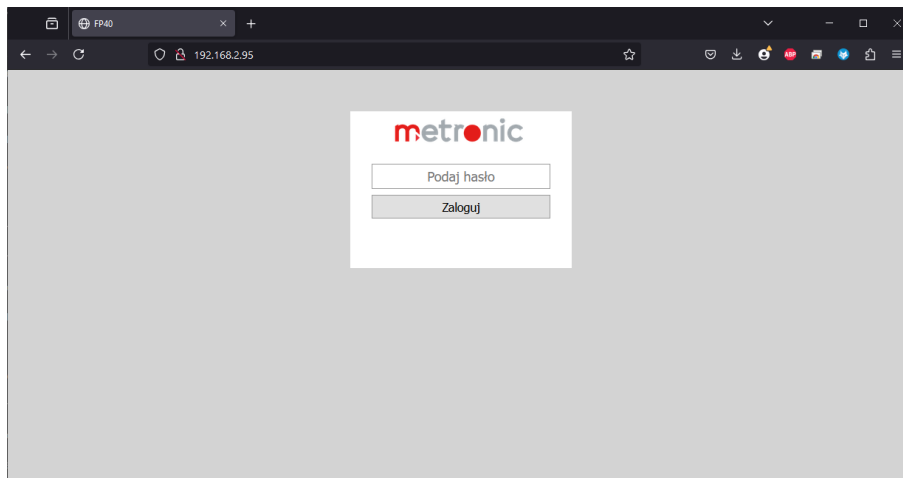

After logging in, the device's web server opens the *Archive* window by default. Below the menu bar there is information on device type, device description for identification in case of having more similar devices.

Nazwa	Data	Rozmiar
01AE01_240912.csv	2024-09-12 14:55	0.30 kB
01AE02_240913.csv	2024-09-13 00:00	0.07 kB
01AE03_240914.csv	2024-09-14 00:00	0.07 kB
01AE04_240915.csv	2024-09-15 00:00	0.07 kB
01AE05_240916.csv	2024-09-16 14:36	0.88 kB
01AE06_240917.csv	2024-09-17 12:07	0.24 kB
01AD07_240917.csv	2024-09-18 00:00	2335.51 kB
01AE07_240917.csv	2024-09-17 12:13	0.15 kB
01AD08_240918.csv	2024-09-18 13:59	2270.91 kB
01AE08_240918.csv	2024-09-18 13:46	0.16 kB
01AD09_240918.csv	2024-09-18 14:03	10.15 kB

At the top menu bar allows to choose screens to be displayed:

- A displays process values from application A
- B displays process values from application B
- X displays process values from application X
- Archive displays the list of archive files to be download
- Logout Log out form web server
- EN language selecting button

Note:

There are seven languages available: EN (English), DE (German), ES (Spanish), FR (French), IT (Italian), PL (Polish), PT (Portuguese). Language is selected according to user system configuration. If the user language is other than one of available, then English is set by default.

7.2 Downloading archive files

The list of archive files is available in the Archive tab. Files can be downloaded to user computer by clicking on the name of the archive file. The files may be sorted by clicking on the column header in the table.

Nazwa	Data	Rozmiar
01AE01_240912.csv	2024-09-12 14:55	0.30 kB
01AE02_240913.csv	2024-09-13 00:00	0.07 kB
01AE03_240914.csv	2024-09-14 00:00	0.07 kB
01AE04_240915.csv	2024-09-15 00:00	0.07 kB
01AE05_240916.csv	2024-09-16 14:36	0.88 kB
01AE06_240917.csv	2024-09-17 12:07	0.24 kB
01AD07_240917.csv	2024-09-18 00:00	2335.51 kB
01AE07_240917.csv	2024-09-17 12:13	0.15 kB
01AD08_240918.csv	2024-09-18 13:59	2270.91 kB
01AE08_240918.csv	2024-09-18 13:46	0.16 kB
01AD09_240918.csv	2024-09-18 14:03	10.15 kB

The file name contains the archive type (AE – events archive, AD – data archive, AT – totalizers archive) and the date the archive was created. The *Date* column indicates the date and time of the latest saved record in the archive file. Details about archive files can be found in the [Archive](#) chapter.

7.3 Viewing process values and totalizers

The web server allows to view all process values and totalizers in table grouped in applications A, B and X. Switching among screens is possible from menu bar. The process values are refreshed automatically. Measured values are displayed in few colours:

blue	value is correct, normal operation, no alarms
black	the value calculated status (e.g. fixed channel value, active cut-off function, extrapolation out of range, the value is depended on another value with calculated status).
green	alarm activated for the process value
orange	alarm activated for the process value
red	alarm activated for the process value

If the channel is in an error state, a failure symbol is displayed.

A **B** X Archiwum Wyloguj
PL

FP40
FP40

B.ΔP: 419.48 kW	B.ΔT: 11.79 °C
B.PS: 258.87 kW Σ1: 313.34 GJ Σ2: 313338 MJ	B.PR: 678.35 kW
B.qmS: 30.5 t/h Σ1: 157.94 t Σ2: 157938 kg	B.qmR: 30.5 t/h
B.qvS: 30.55 m³/h	B.qvR: 0.01 m³/s
B.pS: 119.8 kPaJa	B.pR: 119.1 kPaJa
B.TS: 7.2 °C	B.TR: 19.0 °C
B.ρS: 999.88 kg/m³	B.ρR: 998.39 kg/m³
B.hS: 30.57 kJ/kg	B.hR: 80.00 kJ/kg

8 SUPPORTING SOFTWARE

On the manufacturer's website www.metronic.pl there are two programs dedicated to the device possible to be downloaded:

- FP40 Config, program to configure, check or modify the device settings (available free of charge),
- FP-Raport, program for reading archive files, to analyze and report data (available as an accessory).

8.1 FP40 Config

FP40 Config is a free PC program which helps to configure the device. Program allows to create a new settings file or open and edit the setting file downloaded from the device. Program interfaces is designed to looks almost the same as screens in the device, what makes configuration process similar on both.

Prepared settings file may be uploaded to the device using USB memory flash drive (pen drive).

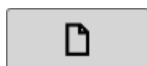
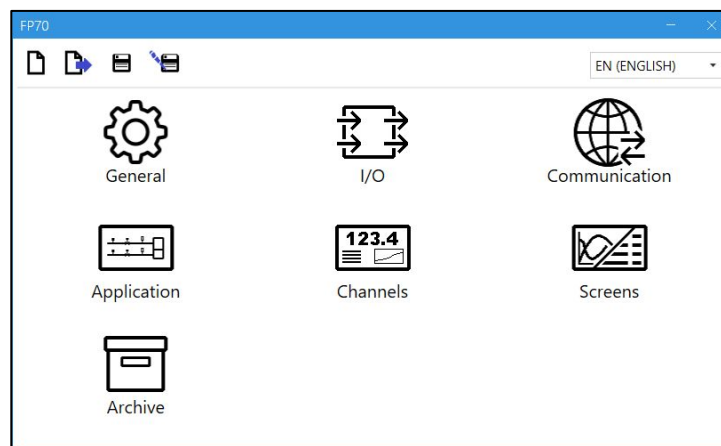

Starts a new default settings



Opens the settings file



Save settings (settings will be saved in the currently opened file, if the settings file is opened, it will be overwritten)



Save settings as a new file (create a new settings file)

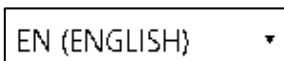

Changes the language.

Notes:

Changing the firmware version of the device may require to download a new version of the configuration program. Before loading the settings file, compare the first two digits specifying the firmware version of the device with the first two digits specifying the version of the program to be configured (they should be the same).

Program allows also to open archived settings file, verify and edit it, and save as a setting file to upload it to the device.

8.2 mReport

The mReport software extends of flow computer archive functionality and allows to analyse and report archived data. Program main features:

- Opening the data archive, totalizers archive, events archive and service archive
- Combining archive files to get combined longer time scale in one file
- Data selection and filtering (smaller / larger than selected; from range; out of range; minimum / maximum / average in time interval)
- Generating a graph of archival data, printing chart, export chart to PDF, HTML, JPG
- Data table presentation, printing the table
- Online reading of process data from the device (Ethernet)
- Downloading archive files directly from the device (Ethernet)



Date	Time	DST	Aqm (M)	Aqm (M)%
23-01-09	00:05:00	0	0.060	56.92
23-01-09	00:02:00	0	0.034	38.02
23-01-09	00:03:00	0	0.059	66.19
23-01-09	00:04:00	0	0.041	45.27
23-01-09	00:01:00	0	0.163	182.62
23-01-09	00:06:00	0	0.028	31.30
23-01-09	00:07:00	0	0.221	246.91
23-01-09	00:08:00	0	0.027	30.27
23-01-09	00:09:00	0	0.076	85.43
23-01-09	00:10:00	0	0.005	6.07
23-01-09	00:11:00	0	0.166	208.33
23-01-09	00:12:00	0	0.020	22.96
23-01-09	00:13:00	0	0.144	161.52
23-01-09	00:14:00	0	0.251	280.34
23-01-09	00:15:00	0	0.072	80.26
23-01-09	00:16:00	0	0.041	45.27
23-01-09	00:17:00	0	0.253	284.04
23-01-09	00:18:00	0	0.168	188.31
23-01-09	00:19:00	0	0.132	147.87
23-01-09	00:20:00	0	0.021	24.44
23-01-09	00:21:00	0	0.004	4.96
23-01-09	00:22:00	0	0.009	10.42
23-01-09	00:23:00	0	0.056	62.44
23-01-09	00:24:00	0	0.234	263.21
23-01-09	00:25:00	0	0.047	52.62

The mReport is optional accessory. Without license program works for 5 minutes with full functionality. For operation without time restrictions it requires registration and entering Activation code, which is obtained from the manufacturer after sending the *Program code* by e-mail. The license is for one PC and cannot be transferred.

FP70-RP FREE TRIAL 09:34

Language: EN (ENGLISH)

Program code: 2517111897

Activation code:

Activate the software

Typical use of the program is to analyse archive files as a table or chart. The use of program is intuitive. There are two bars with pictograms, vertical on the left side of the screen and horizontal at the top above the chart screen.

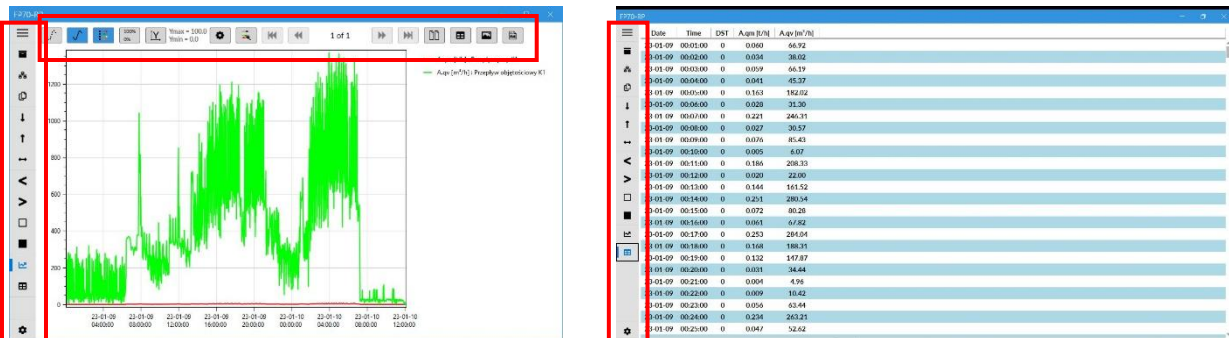

The left bar is menu bar for general program functions for archive files operations. Top bar includes pictograms with functions for chart view operations.

Horizontal menu bar:

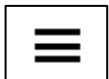

On/off help information on menu pictograms.



Archive file. Information on current file and loading a new file with archive data.



Remote connection. On-line data process overview or downloading archive file from the device archive memory.



Combine archives. Combining two archive files into new one file.

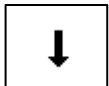

Minimums... Creating a new data file containing minimum value of one minutes, one hours or one days of time interval.

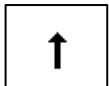

Maximums... Creating a new data file containing maximum value of one minutes, one hours or one days of time interval.

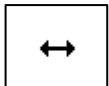

Averages... Creating a new data file containing averaged value of one minutes, one hours or one days of time interval.



Find less then... Creating a new data file containing selected values below entered threshold.



Find greater then... Creating a new data file containing selected values above entered threshold.

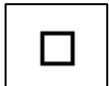

Find outside range... Creating a new data file containing selected values outside entered range.



Find from range... Creating a new data file containing selected values inside entered range.



Chart. Displays process data or totalizers as a chart.



Table. Displays all file data in table form.

Chart top bar menu:

Show/Hide markers. Each marker represents measuring point.

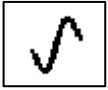

Show/Hide lines. Displays line connecting measuring points.



Show/Hide legend. Displays the chart's legend on the right side of the chart window.

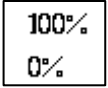

Normalized scale. Displays all trend lines normalized to 0-100% scale.

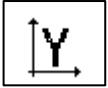

User scale. Displays chart in range of entered Y axis range.



User scale settings. Setting for the user axis Y range.

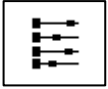

Trend color settings. User preferences settings for trend line colors, line thickness and markers size.



Multi page mode. Divides chart into multi page in time scale.



Current view table. Displays data seen in the chart in table form.



Save trend to graphic file. Saves chart current view as a file in jpg format.



Generate report. Creates chart and/or table report in pdf format.

Mouse functions on chart area:

- CTRL + mouse reel - zoom in or out of the graph
- CTRL+ left mouse button - indication of fragments to enlarge
- CTRL+ right mouse button - return to the initial screen
- CTRL+ left mouse button along the X or Y axis – indication of the area to be zoomed in
- left mouse button - display information about the chart point
- right mouse button – moving the chart observation field

9 MECHANICAL INSTALLATION

! Before starting the installation work, read the information described in the section [SAFETY INFORMATION](#).

9.1 Panel mount version (FP40P)

The device should be mounted in boards of not less than 1mm wall thickness. The required cut-out size is $186^{+1.1}$ mm x $92^{+0.9}$ mm. Installation depth about 72 mm together with cable terminals, but ca. 10 to 20 mm space for cables should be foreseen. To maintain proper ventilation, a distance of at least 100 mm from other devices should be left.

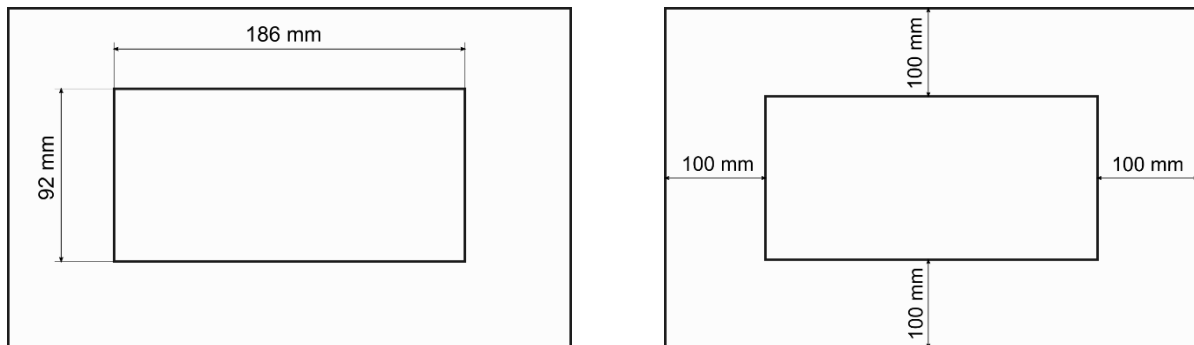

There are four fixing clamps included for device fastening.

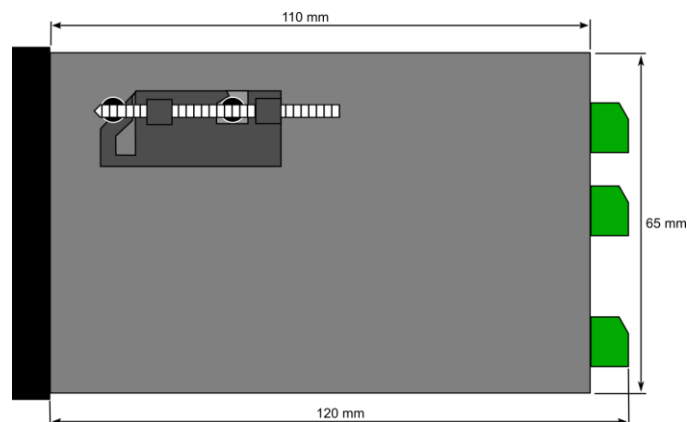

10 WIRING

! Before starting the assembly work, read the information described in the section [SAFETY INFORMATION](#).

▪ Connection of signals shall only be carried out by trained personnel.

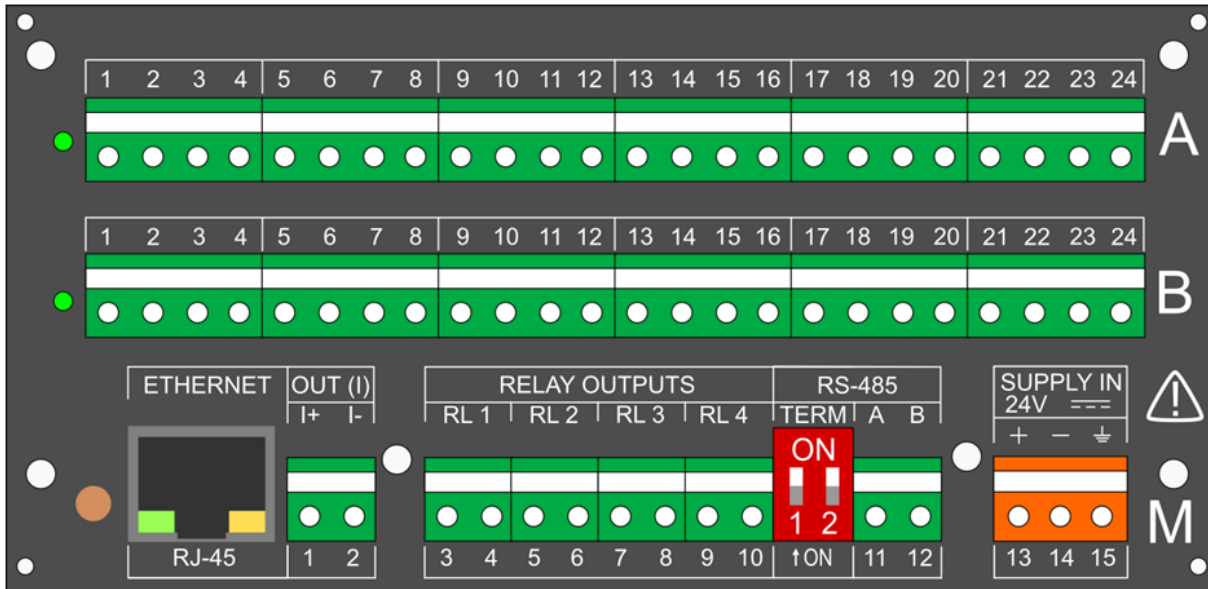

In the FP40, the power supply and all other signals are wired to the plug-in screw terminals on the rear panel of the unit.

Cables with a maximum cross-section of 1.5 mm² may be connected to the connectors. Both stranded and solid wire cables can be used for connections. Stranded wires should be protected with cable sleeves. It is recommended to use 0.35 to 0.5 mm² stranded wires with cable sleeves.

10.1 Galvanic separation in the instrument

The galvanic separation shown below applies to the FP40 version.

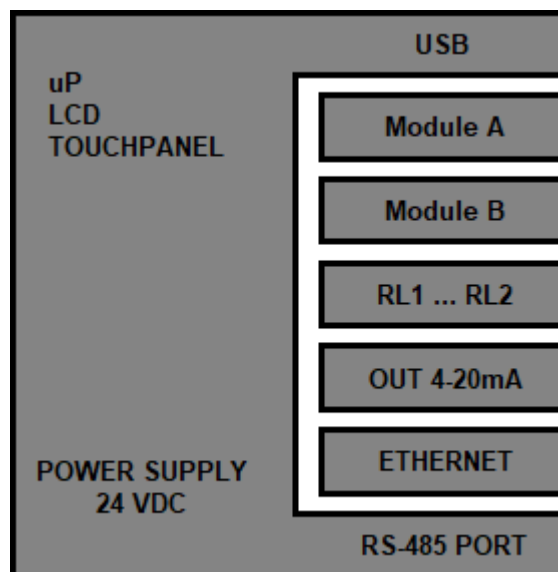

10.2 Power supply

The FP40 device is supplied from 24 VDC source. It is recommended to use high-efficiency industrial switched-mode power supplies with a minimum power of 15 W.

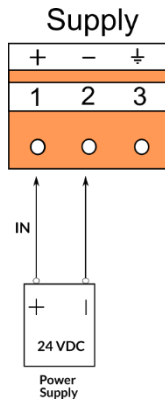

- !** To ensure safety, the power supply of the device must meet the conditions for SELV (Safety Extra Low-Voltage) low-voltage sources powered by 24 VDC in accordance with IEC60950-1.

10.3 FP40 Input Modules

For both device versions cables with a maximum cross-section of 1.5 mm², either stranded or solid wire may be used. In panel mount version with screw terminals stranded wires should be protected with bootlace ferrules. It is recommended to use 0.35 or 0.5 mm² stranded wires for all I/O wiring. Signal cables have to be twisted pair type, shielded cable may be recommended in some harsh industrial environments.

10.3.1 IN6I(24V) – six channel 0-20mA or 4-20mA input type module

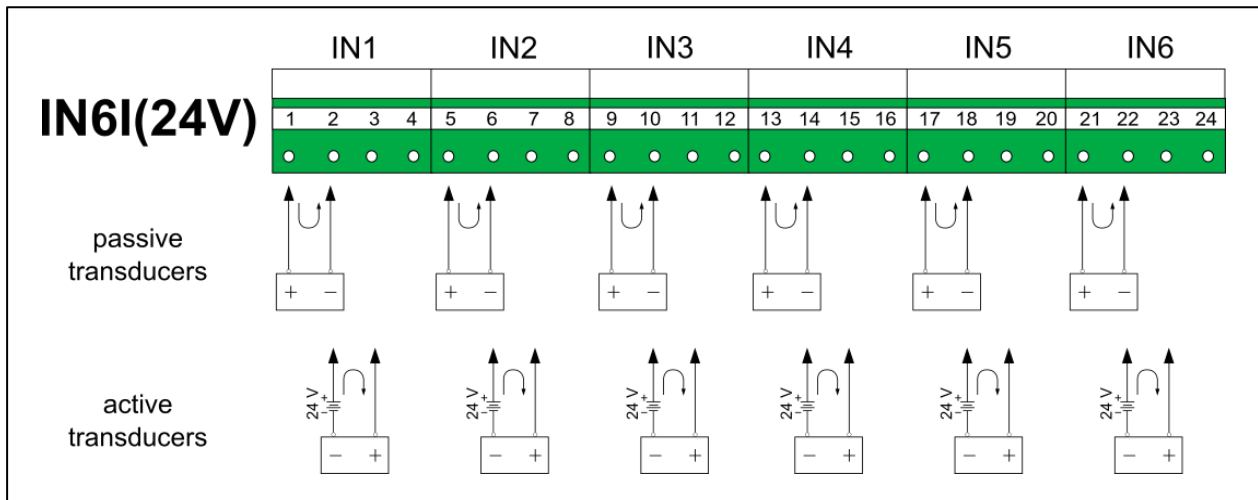

Terminal No						Description
1	5	9	13	17	21	+24V OUT (22 mA max) Transducer power supply. Each output is protected by resettable polymer 50 mA fuse.
2	6	10	14	18	22	I+ Current loop signal input (+)
3	7	11	15	19	23	I- Current loop signal input (-)
4	8	12	16	20	24	GND A Signal ground

Note:

If screened cable is used to connect transducer, then GND A terminal may be used to connect the screen. But it is more recommended to connect screen to functional ground or metal cabinet ground (PE)

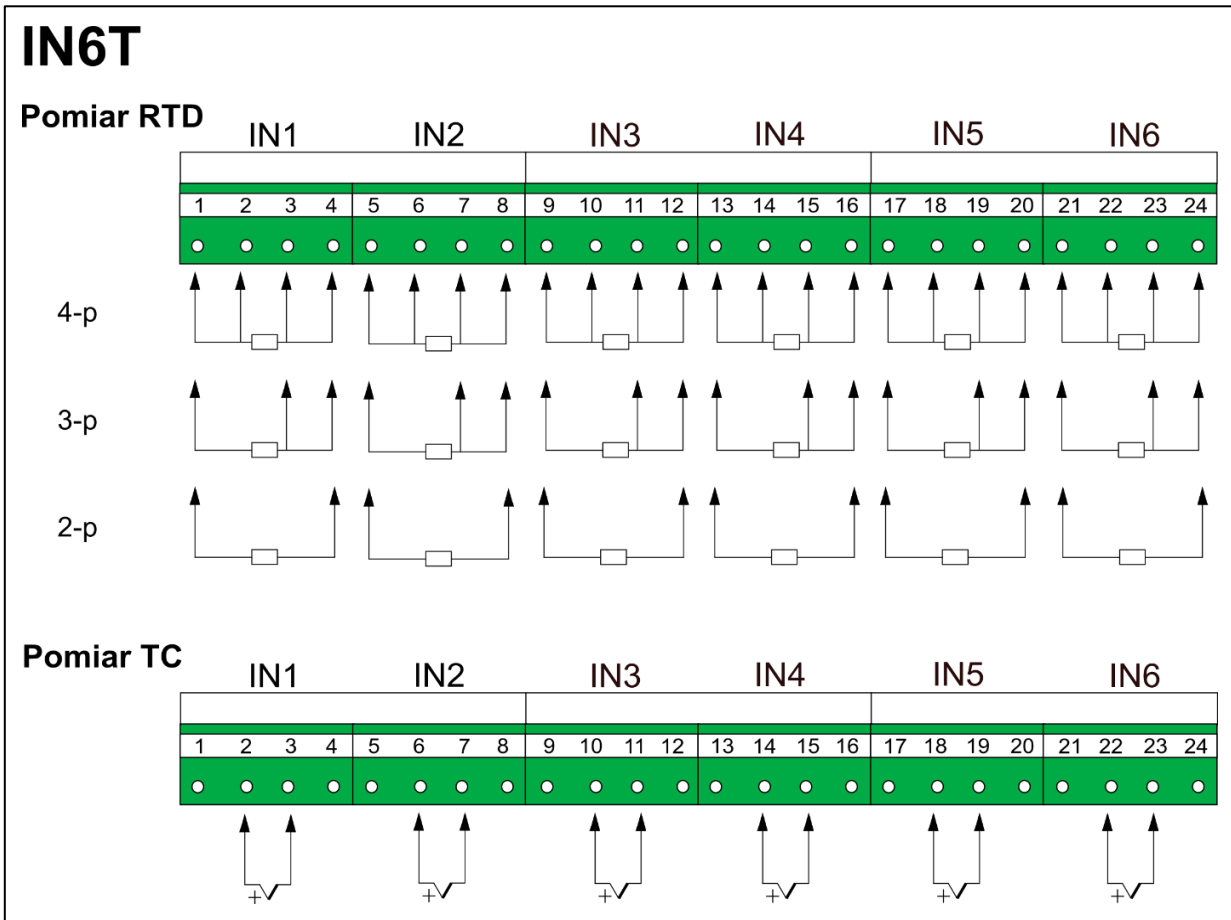
10.3.2 IN6T / IN3T – six/three channel temperature module

Terminal No						Description
1	5	9	13	17	21	I+ Current output for 4-w, 3-w, 2-w
2	6	10	14	18	22	U+ Voltage sens input for 4-w, 3-w, 2-w Voltage signal for TC sensors, input (+)
3	7	11	15	19	23	U- / I+ Voltage sens input for 4-w, 2-w Voltage sens input and current output for 3-w Voltage signal for TC sensors, input (-)
4	8	12	16	20	24	I- / 2*I- Current return for 4-w, 2-w Double current return for 3-w

NOTE:

IN6T card is factory calibrated for 2 and 3 wire connection. At the user's request, it is possible to calibrate in a 4-wire connection.

IN3T card has only three inputs. Only 1 to 12 terminals are available

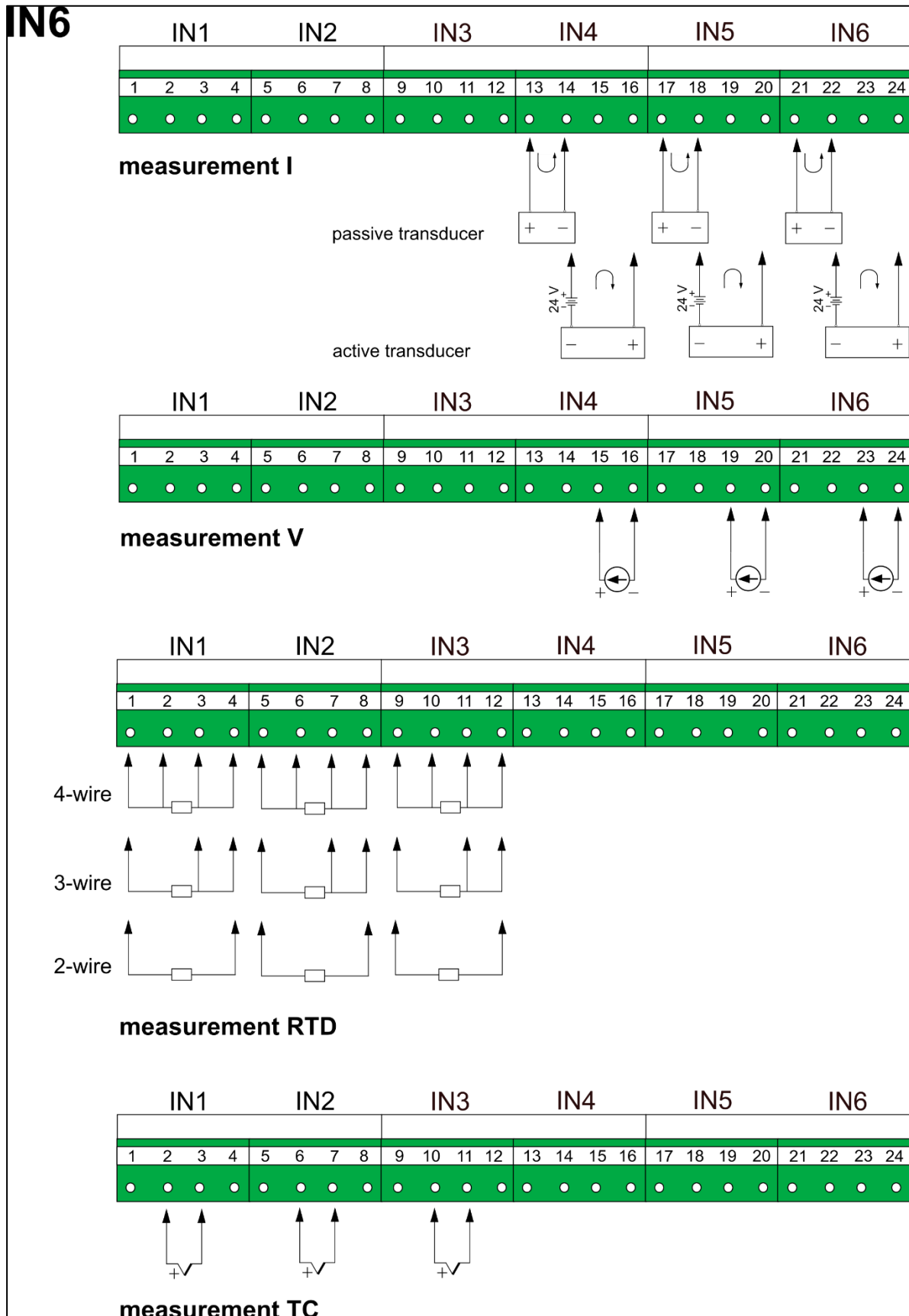
10.3.3 IN6 - six-channel universal analogue input module

Terminal No			Description
1	5	9	I+ Current output for 4-w, 3-w, 2-wire
2	6	10	U+ / mV+ Voltage sens input for 4-w, 3-w, 2-wire Voltage signal for TC sensors, input (+)
3	7	11	U- / I+ / mV- Voltage sens input for 4-w, 2-wire Voltage sens input and current output for 3-wire Voltage signal for TC sensors, input (-)
4	8	12	I- / 2*I- Current return for 4-w, 2-wire Double current return for 3-wire
13	17	21	+24V OUT (22 mA max) Power supply of the transducer. Each output is protected by a 50 mA resettable polymer fuse
14	18	22	I+ Current loop signal input (+)
15	19	23	V+ Voltage signal ± 10 V input (+)
16	20	24	I- Current loop signal input (-) V- Voltage signal ± 10 V input (-)

NOTE:

IN6T card is factory calibrated for 2 and 3 wire connection. At the user's request, it is possible to calibrate in a 4-wire connection.

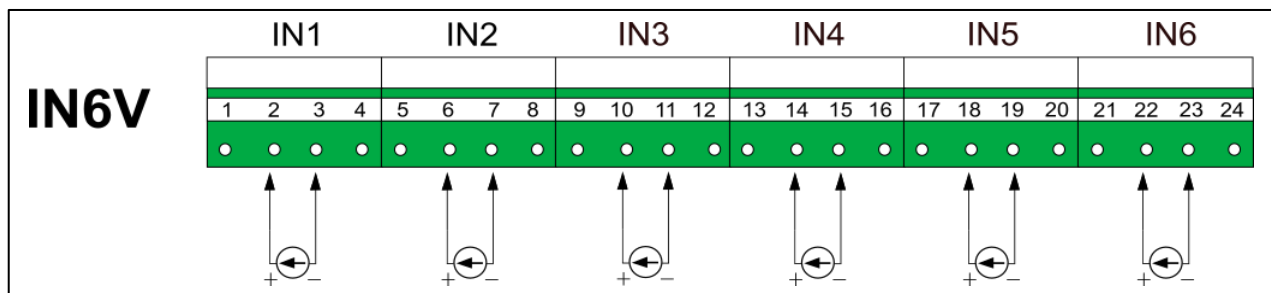
10.3.4 IN6V – six channel voltage type input module

Terminal No						Description
1	5	9	13	17	21	Not used
2	6	10	14	18	22	V+ Voltage signal input (+)
3	7	11	15	19	23	V- Voltage signal input (-)
4	8	12	16	20	24	GND A Signal ground

NOTE:

If screened cable is used to connect sensor, then GND A terminal may be used to connect the screen. But it is more recommended to connect screen to functional ground or e.g. metal cabinet ground (PE).

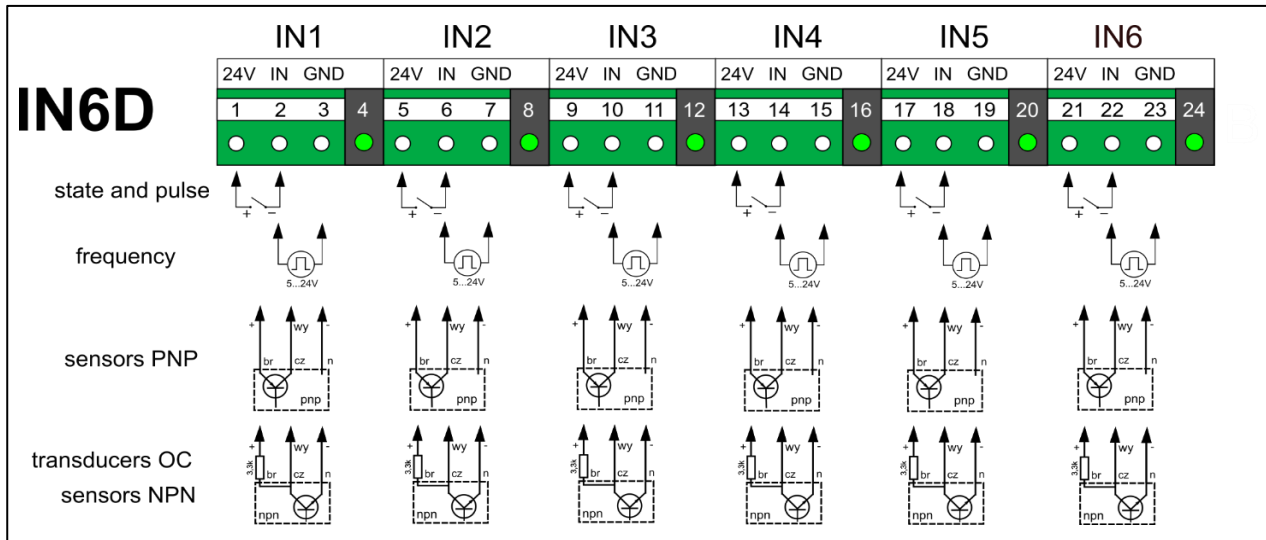
10.3.5 IN6D – six channel binary inputs module

Terminal No						Description
1	5	9	13	17	21	+24V OUT (48 mA max (6x 8 mA)) Transducer power supply. Outputs are protected by common resettable polymer 50 mA fuse.
2	6	10	14	18	22	PULS IN Pulse signal input. Current limit in table below.
3	7	11	15	19	23	GND A Signal ground
LED	LED	LED	LED	LED	LED	LED indicator of the input state.

Note:

The module IN6D standard current limit for inputs is set at 3.6mA. In special cases, it is possible to change the limit value using the jumpers located on the module board inside the device. Available settings are in the table below. The setting apply to all six channels.

J1	J2	I MAX
		0,3mA
•		0,9mA
	•	3,0mA
•	•	3,6mA

To change the settings it is necessary to open the rear panel of device, remove and again install the module. This work should only be carried out by properly qualified staff, carefully and with keeping safety rules.

If screened cable is used to connect the pulse transmitter, then screen should be connected to functional ground or metal cabinet ground (PE).

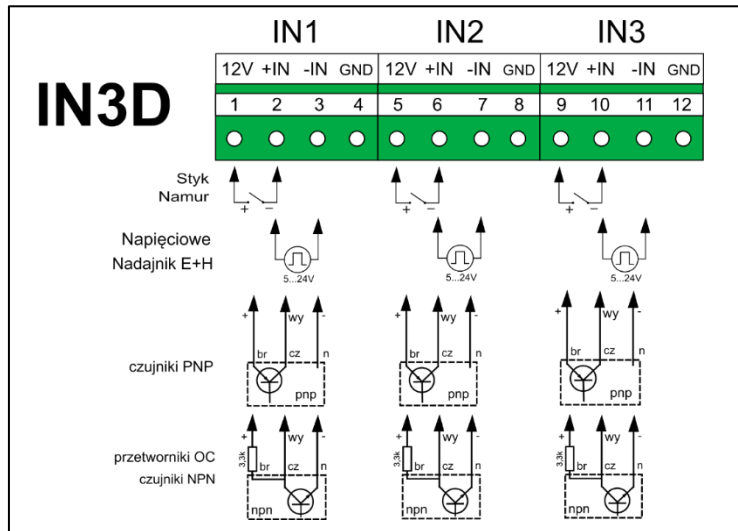
10.3.6 IN3D – three-channel binary input module

Terminal number			Description
1	5	9	+12V OUT (48 mA max) Transducer power supply. The outputs are protected by a common polymer fuse 50 mA.
2	6	10	+IN Pulse Signal Input.
3	7	11	-IN Pulse Signal Input.
4	8	12	GND A Signal Ground

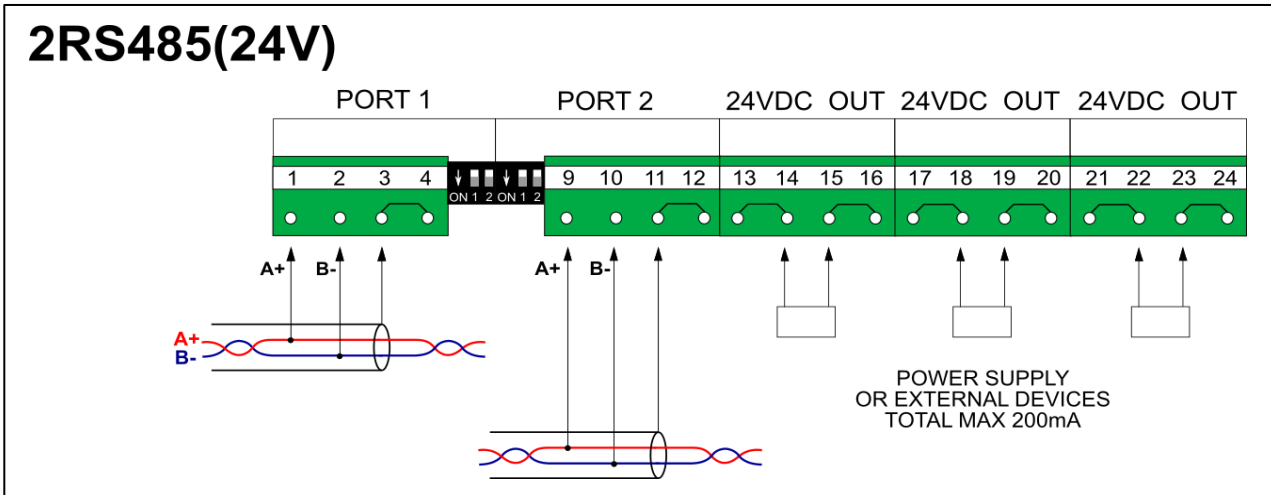
10.3.7 2RS485(24V) – two RS485 port input module (Modbus RTU Master)

Terminal No					Description	
1	T1	9			A+ RS485 terminal A	
2	T1	10			B- RS485 terminal B	
3	T2	11			G Signal ground	
4	T2	12			G Signal ground	
			13 14	17 18	21 22	+24 VDC OUT (200 mA max) Auxiliary transducers power supply (+). Terminals 13, 14, 17, 18, 21, 22 internally shorted. Overcurrent protected.
			15 16	19 20	23 24	-24 VDC OUT (200 mA max) Auxiliary transducers power supply (-). Terminals 15, 16, 19, 20, 23, 24 internally shorted.

Note:

Port 1 and port 2 are galvanically separated. Auxiliary 24 VDC output is galvanically separated from Port 1 and Port 2. More details on wiring RS-485 are described below for [port RS-485 in module M](#).

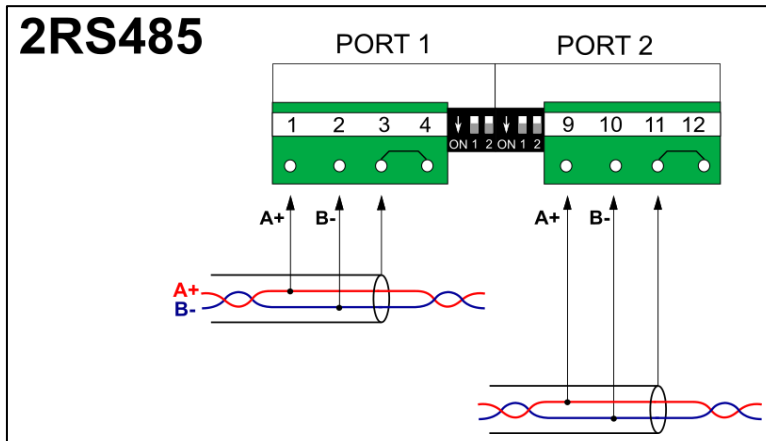
10.3.8 2RS485 – two RS485 port input module (Modbus RTU Master)

Terminal No				Description
1	T1	9		A+ RS485 terminal A
2	T1	10		B- RS485 terminal B
3	T2	11		G Signal ground
4	T2	12		G Signal ground

Note:

Port 1 and port 2 are galvanically separated. More details on wiring RS-485 are described below for [port RS-485 in module M](#).

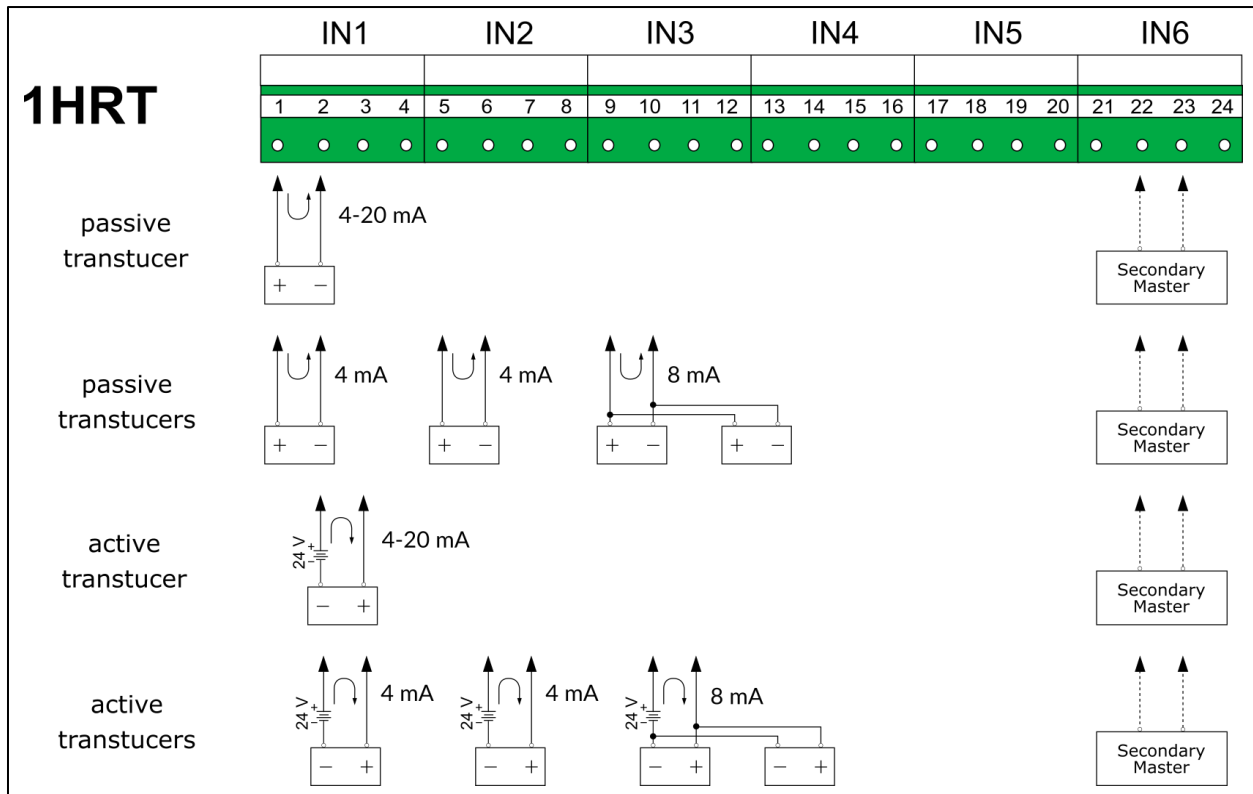
10.3.9 1HRT – HART (4-20 mA) port input module

Terminal No						Description
1	5	9	13	17	21	+24V OUT Transducer power supply. Inputs are protected by common resettable polymer fuse.
2	6	10	14	18	22	HRT+ HART+ signal input (passive transducer and active transducer). Connecting the device in Secondary Master mode.
3	7	11	15	19	23	HRT- HART- signal input (active transducer and passive transducer powered from an external power source). Connecting the device in Secondary Master mode.
4	8	12	16	20	24	SHIELD Connecting the cable shield.

Note:

The module has an internal 250 Ω resistor (disabled by default).

The module terminal blocks are connected in parallel internally. It is possible to create a multidrop connection using the module's connectors.

The device can be configured as Primary Master or as Secondary Master - turning on/off the internal resistor depending on the application should be taken into account.

It is possible to connect the cable shield to the module terminal blocks. If the device is mounted in a metal cabinet, it is recommended to connect the screen directly to the cabinet, by passing the module connector. The screen must be connected to GND at both ends of the cable. If there is a risk of equalizing current flowing through the screen, the screen should be grounded on one side only (at the device).

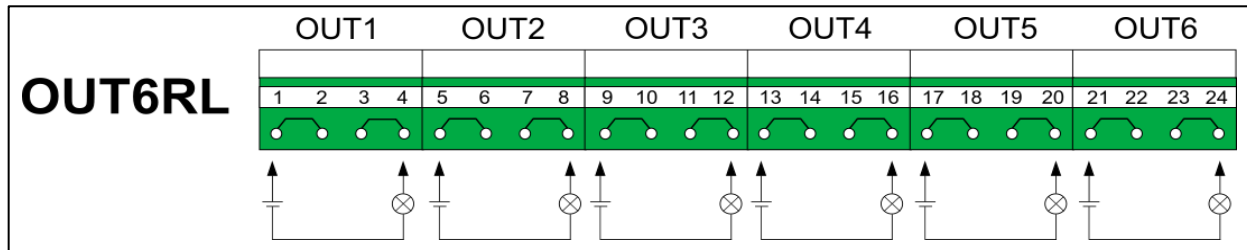
10.3.10 OUT6RL – six channel relay outputs module

Terminal No						Description
1	5	9	13	17	21	Relay terminal output (AC/DC)
2	6	10	14	18	22	
3	7	11	15	19	23	Relay terminal output (AC/DC)
4	8	12	16	20	24	

Note:

Outputs 1 - 6 are galvanically separated.

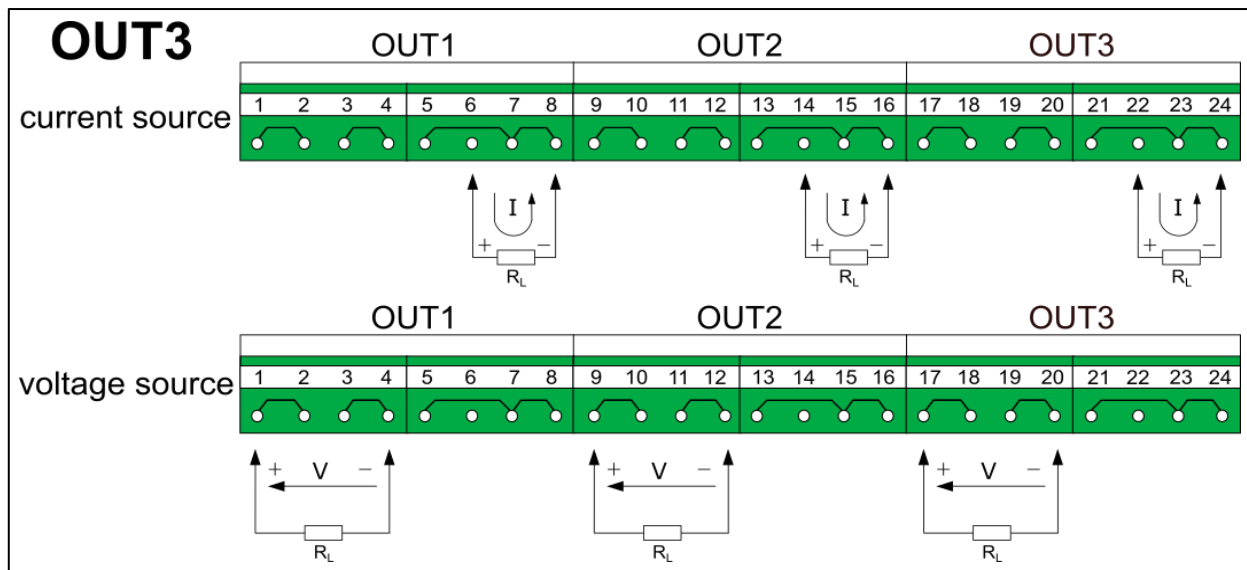
10.3.11 OUT3 – three channel analogue outputs module

Terminal No						Description
1		9		17		V+
2		10		18		Voltage signal 0 .. +10 V output (+)
3		11		19		V-
4		12		20		Voltage signal 0 .. +10 V output (-)
	6		14		22	I+ Current loop signal source 0-24 mA output (+)
	5		13		21	I- / GND A Current loop signal source 0-24 mA output (-)
	7		15		23	
	8		16		24	

Note:

Outputs 1, 2 and 3 are galvanically separated. Each output may be configured to one mode only, either voltage or current source. Current output active - it must not be powered from an external voltage source.

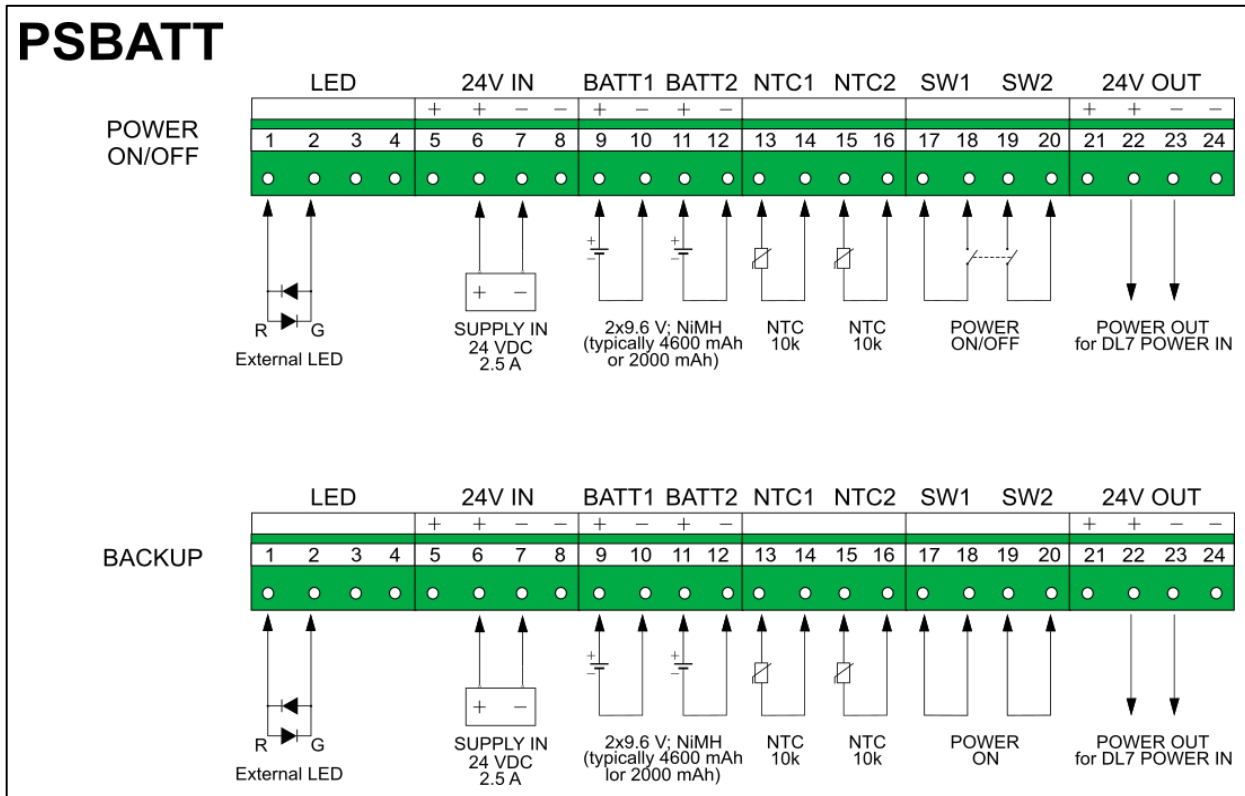
10.3.12 PSBATT – back-up battery module

Terminal No	Description
1	R Connecting an external LED
2	G Connecting an external LED
3	Not used
4	
5	+24 VDC SUPPLY IN (2.5 A max)
6	Module PSBATT and device power supply (+)
7	-24 VDC SUPPLY IN (2.5 A max)
8	Module PSBATT and device power supply (-)
9	2x9.6 V NiMH (typically 4600 mAh or 2000 mAh)
11	Connecting NiMH storage batteries (+), BATT1 package
10	2x9.6 V NiMH (typically 4600 mAh or 2000 mAh)
12	Connecting NiMH storage batteries (-), BATT2 package
13	NTC1
14	Connecting a NTC thermistor for BATT1
15	NTC2
16	Connecting a NTC thermistor for BATT2
17	Power ON/OFF
18	Connecting an external power switch
19	
20	

Terminal No	Description
17 18 19 20	Backup Terminals 17 and 18 and terminals 19 and 20 must be shorted externally
21 22	+24 VDC POWER OUT (1 A max) Power output signal (+), must be connected to terminal 13 on the M module
23 24	-24 VDC POWER OUT (1 A max) Power output signal (-), must be connected to terminal 14 on the M module

Note:

24 V IN and 24 V OUT are not galvanically separated.

The two-color LED indicates the module operating status and battery status:

- short pulses in green colour (0.5 s on / 1.5 s off):
 - pre-charging (battery discharged),
- pulses in green colour (0.5 s on / 0.5 s off):
 - main charging,
- long pulses in green colour (1.5 s on / 0.5 s off):
 - recharging (battery charged),
- green color of the diode (continuous signal):
 - the battery is fully charged (supplying the device from a battery),
- pulses in red colour (0.5 s on / 0.5 s off):
 - battery heavily discharged (supplying the device from a battery),
- red color of the diode (continuous signal):
 - failure state, e.g. failure of temperature sensor or battery, temperature exceeding.

If the PSBATT module is installed, it is forbidden to connect the power supply to the M module (terminals 13, 14, 15). The power supply must be connected only to the PSBATT module (24V IN). The power supply output signal must be connected from the PSBATT (24V OUT) module to terminals 13, 14 on the M module. Terminal 15 on the M module should be connected to GND or PE. Use only dedicated power supply.

The double external switch is used to power the device, it does not disconnect battery charging.

From April 1, 2020, the PSBATT module is manufactured only in version 1.2. Version 1.2 of the module is not backward compatible. The presented way of connecting signals applies only to version 1.2 of the module. To connect signals to module in version 1.0 or in version 1.1, contact the Manufacturer.

10.4 Wiring diagrams – power supply module M

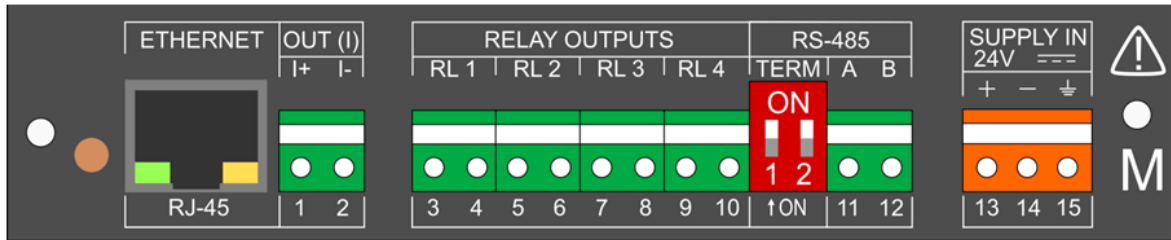

Analog Output Connection

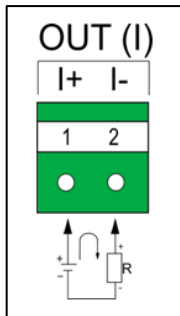

Note:

Passive current source - requires an external voltage source

Connection of relay outputs

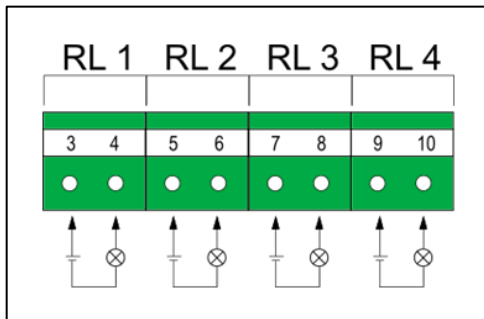

Connection of RS485 data transmission line

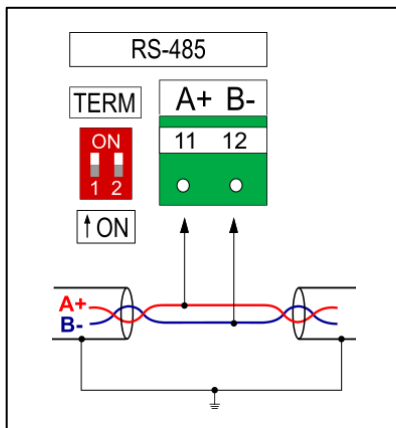

Note:

The RS485 standard allows to connect up to 32 devices (transmitters/receivers). The driver used in the device allows to connect up to 256 receivers, if all other devices are the same type.

The RS485 must be bus configuration. Star configuration is not permitted. The maximum length of the bus depends on the transmission speed, the cable (dimension, capacitance or wave impedance), and the number of loads in the chain. For transmission rates of 9600 bps and 0.125 mm² (AWG26) or larger cross section, the maximum length is 1200 meters. It is recommended to use 0.25 or 0.35 mm² twisted pair cable. It is strictly recommended to use GND line among all devices for conditioning 0 V potential. It is recommended to use good quality cable for digital transmission. Shielded cable may be recommended in some harsh industrial environments.

To minimize signal reflections from the end of the RS485 line, it is required to place the termination near each of the ends of the bus. The device has an internal terminating system, activated by a DIP switch next to the terminal block. Only two devices, located on the both ends of the bus should have termination on. For the proper terminator operation, both switches must be set in the same position.

10.5 Ethernet/LAN port

The 100 Base-T Ethernet port has RJ45 socket with pins EIA/TIA-568A/B compliant. The standard RJ-45 plug patch cord may be connected to this socket.

10.6 Shielding and grounding

In general there is no need to use shielded cables to connect input signals. It is strongly recommended to use signal cables and twisted pair cables for all input and output connections.

In some applications it may be required to use shielded cables to reduce the RF interferences.



It is recommended to connect ground terminals. The purpose of grounding is to reduce EMC emission and improve immunity. It is not protective grounding (PE).





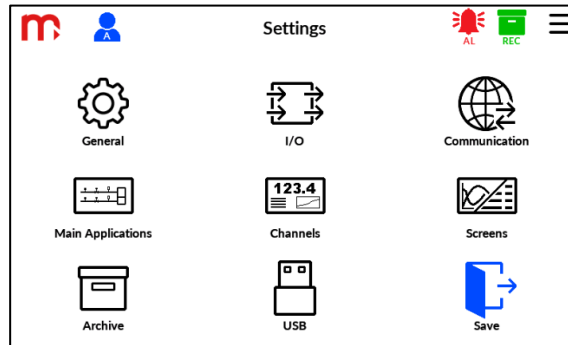

11 SETTINGS AND DEVICE CONFIGURATION

11.1 Navigation in Settings menu

To open the Settings menu screen, the SETTINGS button have to be tapped from the drop-down Main Menu. The Settings main screen has nine function icons to enter to detailed settings screens. Modifications of settings require ADMIN log in. USER has access only to view the settings.



 <p>General</p>	<ul style="list-style-type: none"> • Change of the language, device description, and device ID. • Setting the sound of buttons and alarm sound. • Activation of DST (daylight saving time). • Screen brightness and dimmed level. Background colour setting (light / dark). • Change the date and time. • Service archive view (information about settings changes, device resets, etc.). • Display touch panel calibration • Service functions when SERVICE logged in (e.g. factory reset, meter value entry, calibration of analogue inputs)
 <p>I/O</p>	<ul style="list-style-type: none"> • Change of the language, device description, and device ID. • Setting the sound of buttons and alarm sound. • Activation of DST (daylight saving time). • Screen brightness and dimmed level. Background colour setting (light / dark). • Change the date and time. • Service archive view (information about settings changes, device resets, etc.). • Display touch panel calibration • Service functions when SERVICE logged in (e.g. factory reset, meter value entry, calibration of analogue inputs).
 <p>Communication</p>	<ul style="list-style-type: none"> • Ethernet connection configuration (e.g. IP address). • RS485 port configuration (e.g. Modbus address, transmission speed). • Configuration of e-mail notifications (address of the sender, recipient of the message, frequency of the recurring report). • Configuration of remote reading from Modbus TCP converters (server addresses, registers).

 <p>Main Applications</p>	<ul style="list-style-type: none"> • Selection of the type of measuring system for measuring systems A and B. • Enter a description for the application. • Choosing the type of medium. • Choice of flow measurement method. • Optional addition of a table from the user's medium in the form of a file with the .csv extension (two-dimensional array containing density / enthalpy / specific heat / viscosity depending on temperature / temperature and pressure).
 <p>Channels</p>	<ul style="list-style-type: none"> • Configuration of all channels in measuring systems A and B. • Configuration of all auxiliary channels X. • Set up channel descriptions. • Channel unit selection. • Select a filter for channel values. • Change the resolution for channel values. • User units modifications. • Setting the emergency value and cut-off. • Set the minimum and maximum for the trend field in the Single Channel • Add channel to archiving. • Adding channel value to e-mail report. • Configure of optional totalizers (available in selected channels) • Select the type of totalizers • Totalizer unit selection • Totalizer resolution. • Add totalizer to archiving. • Adding totalizer value to e-mail report. • Configure alarm settings (up to two different alarms for each channel). • Adding information about alarm to the event archive. • Set to change the frequency of archiving on alarm. • Assigning a relay output to an alarm. • Adding information about alarm to an e-mail notification.
 <p>Screens</p>	<ul style="list-style-type: none"> • Configuration of User Tables screens (up to six screens containing 16-element tables). • Configuration of User Trends screens (up to six screens containing 6-element trend charts).
 <p>Archive</p>	<ul style="list-style-type: none"> • Archive type (daily, weekly, or monthly). • Frequency of data recording for Main Archive (process values) and Totalizers Archive. • Graphical information on channel values declared to be archived.
 <p>USB</p>	<ul style="list-style-type: none"> • Saving and reading files to an external flash memory (memory stick), settings, archive files, print screens. • Deleting archive files and print screen files.
 <p>Save</p>	<ol style="list-style-type: none"> 1. Exit the Main Menu window (save & exit, exit without saving, cancel).

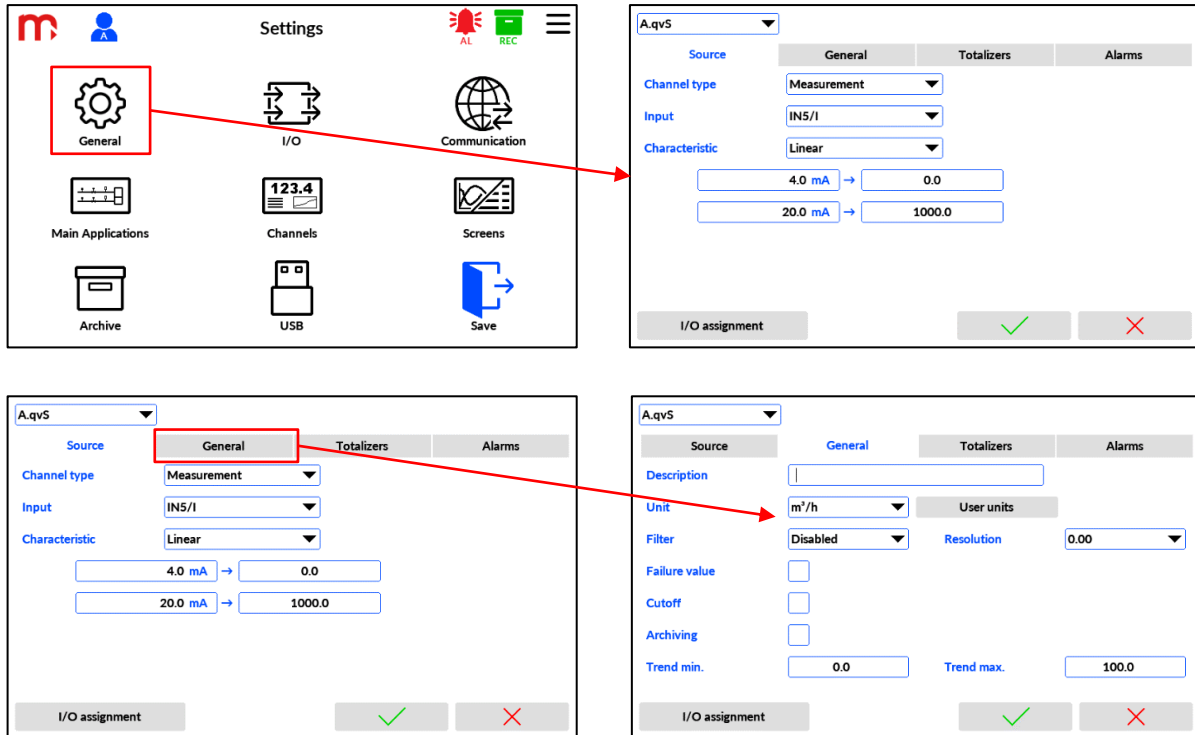

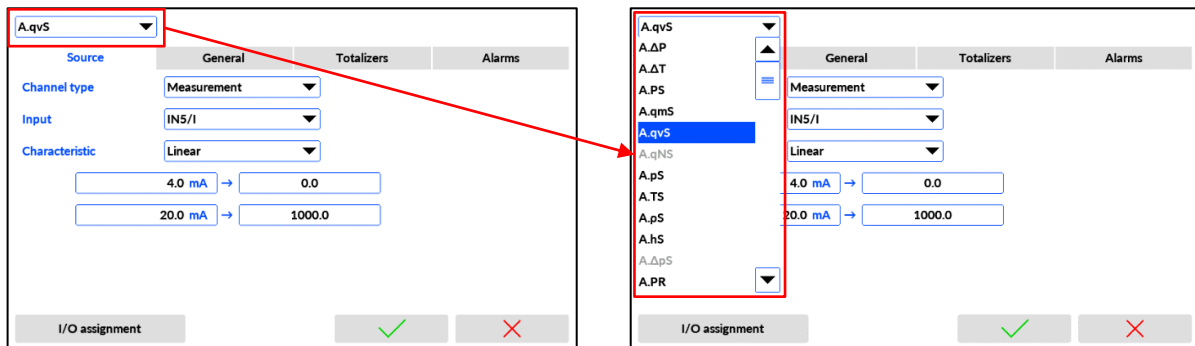

Individual sub windows can contain pages. Switching among pages in the selected settings sub window is possible using the tabs at the top.

The settings screens may contain drop-down lists, which switch among the group of similar settings screens (e.g. channel screens for settings).



In the lower part of the sub window there are buttons:

-  exit and confirm the changes
-  exit and cancel the changes

If the settings screen has tabs, the buttons confirming / cancelling changes apply for all pages within the settings sub window.

11.2 Change settings

Changes of settings are made in individual sub windows using drop-down selection lists, check-boxes, buttons and fill-in boxes for numbers or strings. For some, the on-screen keyboard is used to enter required data. The on-screen keyboard is displayed after tapping on editable fields.

A.qm
Source: General
Description: Water flow
Unit: t/h
Filter: Disabled
Resolution: 0.00
Failure value:
Cutoff:
Archiving:
E-mail notification:
Trend min.: 0.0
Trend max.: 5.0
I/O assignment:

Water flow
q w e r t y u i o p ← 1 2 3 +
a s d f g h j k l ← 4 5 6 ×
z x c v b n m ↑ 7 8 9 -
Alt !@# ✓ ✗ = 0 . +

A.qm
Source: General
Description: Water flow
Unit: t/h
Filter: Disabled
Resolution: 0.00
Failure value:
Cutoff:
Archiving:
E-mail notification:
Trend min.: 0.0
Trend max.: 5.0
I/O assignment:

0.0
1 2 3 ←
4 5 6
7 8 9 ✓
- 0 . ✗

A.qm
Source: General
Description: Water flow
Unit: t/h
Filter: Disabled
Resolution: 0.00
Failure value:
Cutoff:
Archiving:
E-mail notification:
Trend min.: 0.0
Trend max.: 5.0
I/O assignment:

Cutoff: 0.0
Archiving:
E-mail notification:
Trend min.: 0.0
Trend max.: 5.0
I/O assignment:

A.qm
Source: General
Description: Water flow
Unit: t/h
Filter: Disabled
Resolution: 0.00
Failure value:
Cutoff:
Archiving:
E-mail notification:
Trend min.: 0.0
Trend max.: 5.0
I/O assignment:

Add new...
Symbol:
Base unit: No type
Time base: None
Coefficients
A = 1.0
B = 0.0
New Save Delete Close
I/O assignment:

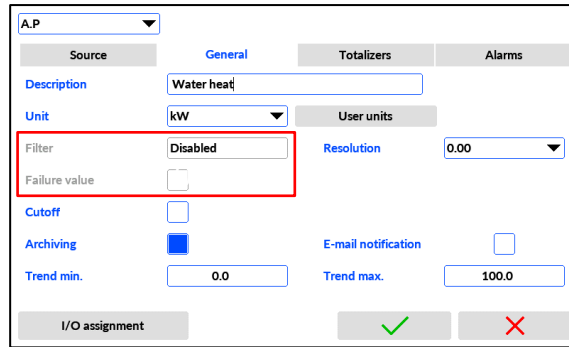

Depending on other settings, some lists / buttons / editable fields may be disabled and not possible to be edited, these are marked in grey then.

11.3 Save settings

New settings are not immediately active when entered. Settings can be viewed and modified without impact on operation of the device. To activate new settings the Save icon have to be tapped and confirmed in pop-up window. Most of the changes make the device restart. In most cases also new archive file is created.

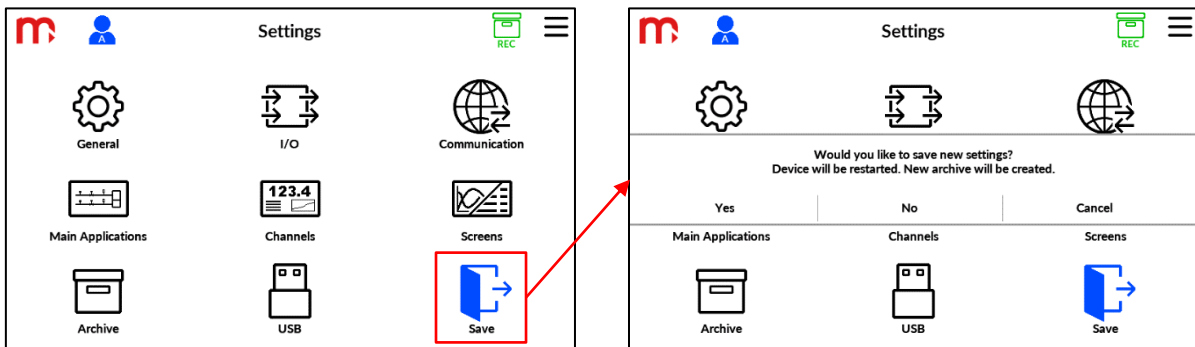

User logged in has an access to settings and may also modify them, but without permission to save. If still new settings are to be saved, then Cancel button should be tapped, Admin password should be logged in and again save process should be repeated.

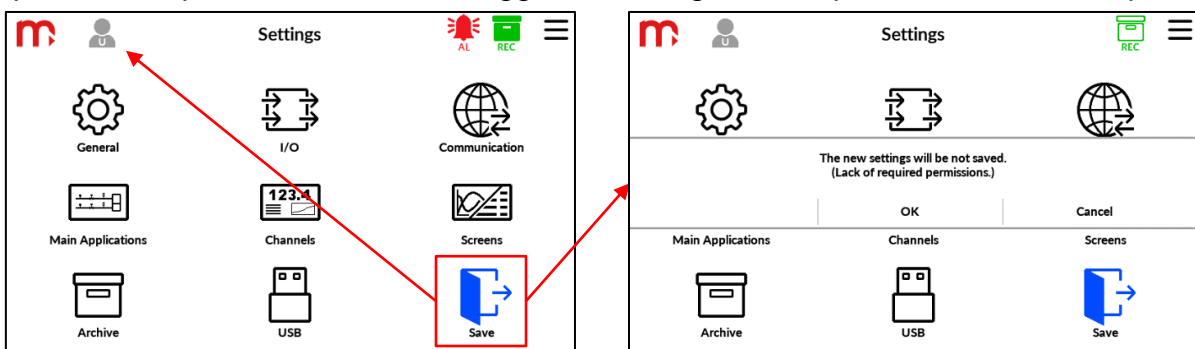

11.4 Order of configuration process (suggested)

The brand new device has all functions disabled, it does not perform any measurements or calculations. It must be configured. Some parameters are not available before other parameters are entered first. For this reason it is convenient to follow the suggested order while first configuration:

1. General
2. I/O
3. Communication
4. Main Application
5. Channels
6. Screens
7. Archive

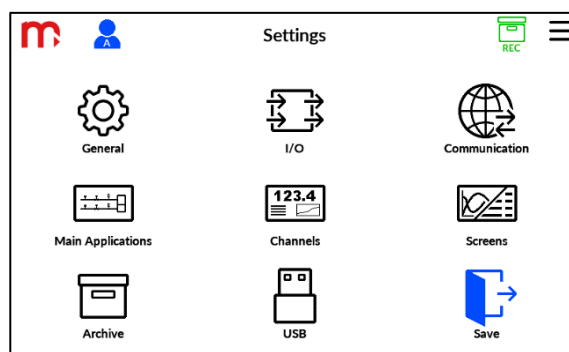

11.5 General settings

In the General settings window, it is possible to configure important settings for the operation of the device, like language, RTC (Real Time Clock - date and time), secondary settings like display, beeper. There are also service functions, like pre-set of totalizers, analogue inputs calibration, Service Archive or settings archive. Some of above are available for Admin, others require Service log in.

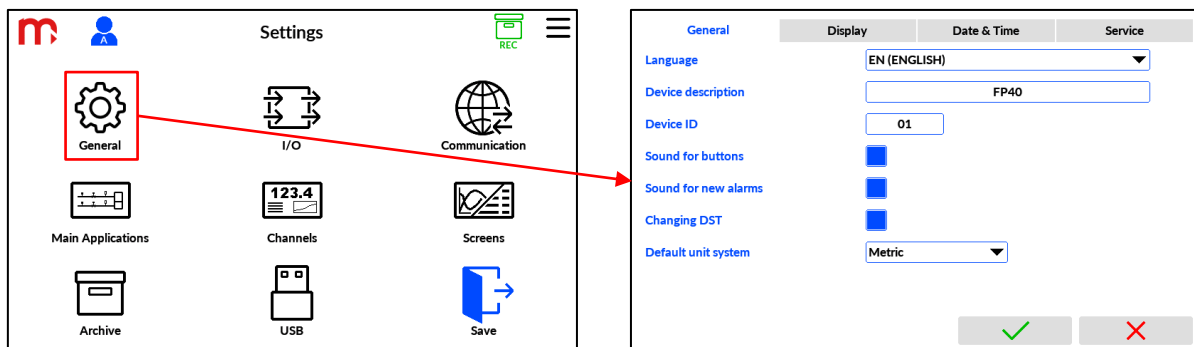

11.5.1 General

Language: EN (ENGLISH) (EN (ENGLISH), DE (DEUTSCH), ES (ESPAÑOL), FR (FRANÇAIS), IT (ITALIANO), PL (POLISH), PT (PORTUGUÊS))^[1]

Description of the device: [text]^[2]

Device ID: [value]^[3]

Sounds for buttons: Off (Off, On)^[4]

Sounds for new alarms: Off (Off, On)^[5]

Changing DST: Off (Off, On)^[6]

Default unit system: Metric (Metric, Imperial)^[7]

- [1]: Selecting language from the drop-down list. The device has seven languages available.
- [2]: Allows to enter user device description (tag). Max 40 characters string allowed.
- [3]: Allows to assign device ID. The ID number is used in the name of the archive files and in the name of the settings file copied from the device.

NOTE:

When using more than one device, it is recommended to assign unique ID number to every device. This will allow to recognize the source of the archive files by the ID number assigned.

- [4]: Enables beeper sound when button is tapped.
- [5]: Enables beeper sound a new alert notification from process values alarm thresholds.
- [6]: Enables automatic DST (Daylight Saving Time) time adjust.
- [7]: This selection affects barometric pressure units and pipeline diameter units. Some other units are prompt as first choice. All other units are available in both, metric and imperial systems.

11.5.2 Display

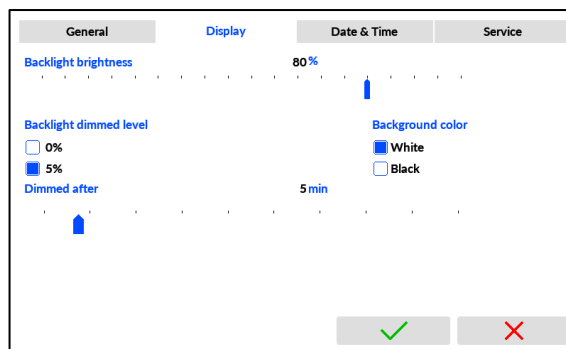

- Brightness:** 80% (10% ... 100%)^[1]
- Dimming brightness:** 5% (0%, 5%)^[2]
- Background colour:** White (White, Black)^[3]
- Dimmed after:** Off (Off, 1 min ... 60 min)^[4]

- [1]: Degree of backlight brightness during normal operation from 10 to 100% (slider).
- [2]: Dimmed level after inactivity time 0% or 5%. 0% means display backlight off. When backlight is off, the front panel LED lights in blue indicating that the device is working.
- [3]: Background colour may be set to white or black.
- [4]: Delay time after last touch panel operation before the dimming. When value is set to Off, the dimming will not be activated.

11.5.3 Date and Time

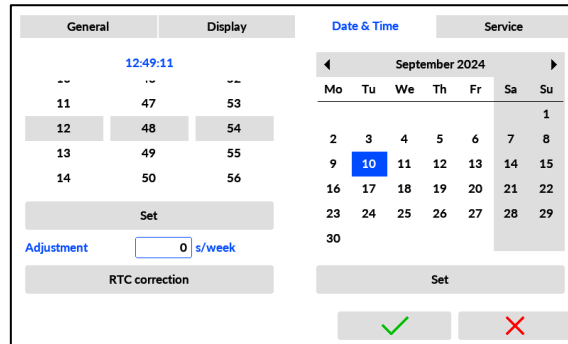

Time: [hour : minute : second]^[1]

Date: [day - month - year]^[2]

RTC correction: [value] s/month^[3]

[1]: Changes are made using three sliders, for hours, minutes and seconds. The currently selected time is highlighted in grey. Changes are applied by tapping Set button.

[2]: The new date is selected from calendar. The currently selected date is highlighted in blue. Changes are applied by tapping Set button.

[3]: RTC correction allows to adjust the internal clock (RTC) in long time scale. A positive value adds and negative value subtract the number of seconds within a week.

Note:

Time and date is updated immediately and do not require device restart. After changing the time or date, it is recommended to create a new archive.

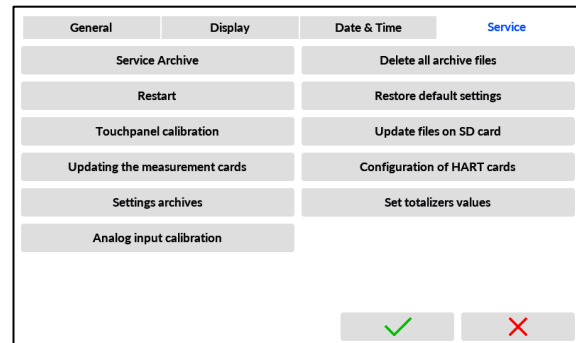
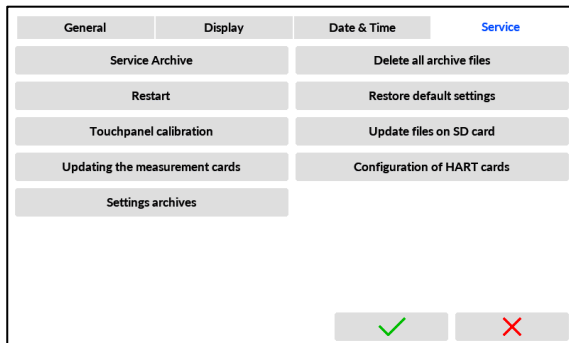

11.5.4 Service

Admin	Service
Service Archive ^[1]	Service Archive ^[1]
Delete all archive files ^[2]	Delete all archive files ^[2]
Restart ^[3]	Restart ^[3]
Restore default settings ^[4]	Restore default settings ^[4]
Touchpanel calibration ^[5]	Touchpanel calibration ^[5]
Update files on SD card ^[6]	Update files on SD card ^[6]
Updating the measurement cards ^[7]	Updating the measurement cards ^[7]
Configuration of HART cards ^[8]	Configuration of HART cards ^[8]
Settings archives ^[9]	Settings archives ^[9]
	Set totalizers value ^[10] s
	Analog input calibration ^[11]

- [1]: The function to view service archive. More information in chapter service archive.
- [2]: Deletes all archived files except settings archive and service archive.
- [3]: Restarts the device.
- [4]: Restore defaults settings. Function does not delete archive files.
- [5]: Allows to recalibrate touchpanel. Automatically exits the window after correct calibration procedure.
- [6]: Function for uploading new the update files to internal memory. Used only when firmware update required.
- [7]: Function for updating firmware of installed cards
- [8]: Function for HART remote device configuration.
- [9]: List of files with previous settings. Function allows to copy selected settings file to USB memory device.
- [10]: Function to pre-set or clear selected totalizers, including Non-Erasing, Daily, Weekly and Monthly totalizers.
- [11]: Function for calibration analogue cards.

11.6 Input and output settings

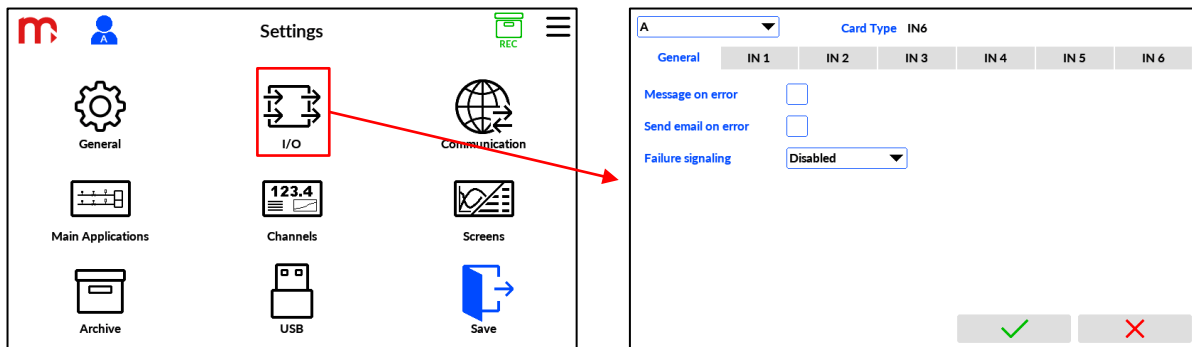

Selecting slot from the list, it is possible to configure individual card settings.

11.6.1 IN6I (24DC) / IN6I - Current Input Module 0/4-20 mA

General

Message on error: Enabled (Disabled, Enabled)^[1]

Sand email on error: Disabled (Disabled, Enabled)^[2]

Failure signalling: Disabled (Disabled, Enabled)^[3]

[1]: Message will be displayed on device screen

[2]: Information on failure may be send by e-mail message to defined addresses.

[3]: After enabling additional fields will appear for selection slot and output. This function will only work with OUT6RL card and relay output on MAIN card.

Inputs settings (IN1...IN6)

Mode: Disabled (Disabled, 0-20[mA], 4-20[mA])

Adjustment: [value]^[1]

[1]: Adjustment allows to trim measurement by adding constant offset. Added value is in measurement units.

11.6.2 IN6T / IN3T – Temperature Inputs Module

General

Message on error: Enabled (Disabled, Enabled)^[1]

Sand email on error: Disabled (Disabled, Enabled)^[2]

Failure signalling: Disabled (Disabled, Enabled)^[3]

[1]: Message will be displayed on device screen

[2]: Information on failure may be send by e-mail message to defined addresses.

[3]: After enabling additional fields will appear for selection slot and output. This function will only work with OUT6RL card and relay output on MAIN card.

Inputs settings (IN1...IN6 / IN1...IN3)

Mode: Disabled (Disabled, 2-wires, 3-wires, 4-wires, TC)^[1]

Adjustment: [value] Ω and [value] mV^[2]

Compensation: Disabled (Disabled, Constant, Channel 1, ..., 100)^[3]

[1]: RTD sensors can be connected in a two-wire configuration without automatic compensation or a three-wire or four-wire configuration with automatic cables resistance compensation.

[2]: Adjustment allows to trim measurement due to the cable resistance in the two-wire configuration. In three-wire or four-wire configuration (automatic compensation), the resistance correction can be used to compensate the sensor error by “offsetting” the characteristics by adding the positive or negative resistance value.

[3]: Available only in TC mode. Cold junction compensation can be set as constant value or can be provide form another channel.

11.6.3 IN6 - Universal Inputs Module

General

Message on error: Enabled (Disabled, Enabled)^[1]

Sand email on error: Disabled (Disabled, Enabled)^[2]

Failure signalling: Disabled (Disabled, Enabled)^[3]

[1]: Message will be displayed on device screen

[2]: Information on failure may be send by e-mail message to defined addresses.

[3]: After enabling additional fields will appear for selection slot and output. This function will only work with OUT6RL card and relay output on MAIN card.

Inputs settings (IN1...IN3)

Mode: Disabled (Disabled, 2-wires, 3-wires, 4-wires, TC)^[1]

Adjustment: [value] Ω and [value] mV^[2]

Compensation: Disabled (Disabled, Constant, Channel 1, ..., 100)^[3]

[1]: RTD sensors can be connected in a two-wire configuration without automatic compensation or a three-wire or four-wire configuration with automatic cables resistance compensation.

[2]: Adjustment allows to trim measurement due to the cable resistance in the two-wire configuration. In three-wire or four-wire configuration (automatic compensation), the resistance correction can be used to compensate the sensor error by “offsetting” the characteristics by adding the positive or negative resistance value.

[3]: Available only in TC mode. Cold junction compensation can be set as constant value or can be provide form another channel.

Inputs settings (IN4...IN6)

Mode: Disabled (Disabled, 0-20[mA], 4-20[mA], -10[V] - +10[V], 0[V]-10[V])

Adjustment: [value]^[1]

[1]: Adjustment allows to trim measurement by adding constant offset. Added value is in measurement units.

11.6.4 IN6V - voltage input module 0-10 V

General

Message on error: Enabled (Disabled, Enabled)^[1]

Sand email on error: Disabled (Disabled, Enabled)^[2]

Failure signalling: Disabled (Disabled, Enabled)^[3]

[1]: Message will be displayed on device screen

[2]: Information on failure may be send by e-mail message to defined addresses.

[3]: After enabling additional fields will appear for selection slot and output. This function will only work with OUT6RL card and relay output on MAIN card.

Inputs settings (IN1...IN6)

Mode: Disabled (Disabled, -10[V] - +10[V], 0[V]-10[V])

Adjustment: [value]^[1]

[1]: Adjustment allows to trim measurement by adding constant offset. Added value is in measurement units.

11.6.5 IN6D – Pulse Input Module

General

Filter: Disabled (Disabled, 1 ms, 3 ms)^[1]

Message on error: Enabled (Disabled, Enabled)^[2]

Sand email on error: Disabled (Disabled, Enabled)^[3]

Failure signalling: Disabled (Disabled, Enabled)^[4]

[1]: For low frequency signals, in particular for the contact type transmitters, an additional filter can be activated. This setting applies to all inputs.

[2]: Message will be displayed on device screen

[3]: Information on failure may be send by e-mail message to defined addresses.

[4]: After enabling additional fields will appear for selection slot and output. This function will only work with OUT6RL card and relay output on MAIN card.

Inputs settings (IN1...IN6)

Mode: Disabled (Disabled, State, Frequency, Impulse counter)

11.6.6 IN3D – Pulse Input Module

General

Message on error: Enabled (Disabled, Enabled)^[1]

Sand email on error: Disabled (Disabled, Enabled)^[2]

Failure signalling: Disabled (Disabled, Enabled)^[3]

[1]: Message will be displayed on device screen

[2]: Information on failure may be send by e-mail message to defined addresses.

[3]: After enabling additional fields will appear for selection slot and output. This function will only work with OUT6RL card and relay output on MAIN card.

Inputs settings (IN1...IN3)

Mode: Disabled (Disabled, State, Frequency, Impulse counter)^[1]

Type: Voltage (Voltage, OC, E+H, NAMUR)^[2]

Filter: Disabled (Disabled, Enabled)^[3]

[1]: Depending on the configuration, the inputs can operate in state on-off detection, frequency measurement or pulse counting mode.

[2]: Hardware type of transducer connected: with Voltage output, with OC (open-collector or contact) output, E+H (current type) output, NAMUR type output.

[3]: For low-frequency signals, in particular signals coming from mechanical contact, it is possible to activate an additional low-pass filter at ca. 100 to 300 Hz cut-off frequency.

11.6.7 2RS485(24V) / 2RS485 - Modbus Master Input Module

General

Message on error: Enabled (Disabled, Enabled)^[1]

Sand email on error: Disabled (Disabled, Enabled)^[2]

Failure signalling: Disabled (Disabled, Enabled)^[3]

[1]: Message will be displayed on device screen

[2]: Information on failure may be send by e-mail message to defined addresses.

[3]: After enabling additional fields will appear for selection slot and output. This function will only work with OUT6RL card and relay output on MAIN card.

RS485 COM

Baud Rate: 19200 (Disabled, 1200, 2400, 4800, 9600, 19200, 38400, 57600, 115200)

Parity: None (Odd, Even, None)

Stop Bits: 1b (1b, 2b)

Timeout: [value] ms^[1]

[1]: Timeout defines time to wait for response form slave device.

Registers

IO^[1]

Port: Disabled (Disabled, 1, 2)^[2]

Device: [value]^[3]

Address: [value]^[4]

Type: uint(16bit), int (16bit), uint (32bit), int (32bit), uint (32bit) sw, int (32bit), int (32bit) sw, float (32bit), float (32bit) sw, int (64bit), double (64bit)^[5]

[1]: Module's measurement input number.

[2]: The number of the port used.

[3]: Slave device address from which the data will be read. Valid range is 1 to 255.

[4]: Register's number from which data will be read. Available format: 3xxxx/3xxxxx or 4xxxx/4xxxxx, where: 3 – input registers, 4 – holding register and xxxx/xxxxx – four/five digit address. The value must be given in decimal system (see section [MODBUS RTU / MODBUS TCP TRANSMISSION PROTOCOL](#)).

[5]: Ten formats of readings are available in the drop-down list, where: uint – unsigned integer, int – signed integer, float – single precision floating point, double – double precision floating point, sw – swapped format (more information in section [Data types](#)).

Choose a format that matches the specification of the sensor or device you are reading.

Notes:

It is possible to group registers to optimize the data transmission. If the register address is the next value to the sum of the previous address and the type size of the preceding register, the registers will be grouped into one query.

11.6.8 1HRT - HART input module

General

Master: Primary (Primary, Secondary)^[1]

Resistor 250 Ω: Disabled (Disabled, Enabled)^[2]

Preamble: [value] B

Message on error: Enabled (Disabled, Enabled)^[3]

Send email on error: Disabled (Disabled, Enabled)^[4]

Failure signalling: Disabled (Disabled, Enabled)^[5]

[1]: The device can be configured as a Primary Master or as a Secondary Master.

[2]: The internal 250 Ω resistor is Disabled by default. The resistor is turned on with using settings in the General tab. The internal resistor is automatically disconnected in case of power failure to the device. If there is a need to maintain the loop current in the event of a power failure, an external resistor R250 Ω should be used.

[3]: Message will be displayed on device screen

[4]: Information on failure may be send by e-mail message to defined addresses.

[5]: After enabling additional fields will appear for selection slot and output. This function will only work with OUT6RL card and relay output on MAIN card.

Field devices

Mode: Disabled (Disabled, Enabled)^[1]

Address: [device address]^[2]

[1]: Set the *Enabled* mode for the connected device. If the transmitter or device connected with the flow computer is disconnected, it is recommended to disable the device (changing the settings of [Channels](#) and *Variables* tab is not required).

[2]: Address of the transmitter or device from which the measurement results are to be read. For a device in HART revision 4, enter the short address (in the range 0-15 DEC), for a device in rev 5, rev 6 and rev 7, enter the long address of the device (HEX).

Variables

#^[1]

Field device: Disabled (Disabled, selection from the list of added devices)^[2]

Type: PV (PV, SV, TV, FV, DVC)^[3]

Code: -- (--, value)^[4]

Command: 03 (01, 03, 09)^[5]

Status: Enabled (Disabled, Enabled)^[6]

[1]: Module measuring channel number.

[2]: Selection from the list of added devices (configured in the Field devices). It is possible to assign a device in the Disabled mode to the variable.

[3]: Type of the read variable.

[4]: For the DVC variable, the code of the read variable must be given.

- [5]: The command used to read the variable. The command 01 and 03 can be selected for the PV variable. The 03 command is fixed for SV, TV and FV variables, The 09 command is fixed for DVC.
- [6]: Enabling or disabling the status analysis in the read HART frame. The Enabled status will result in displaying the variable value in case of correct HART status and displaying the --ERR-- symbol in case of incorrect HART status (the variable value is not displayed). The Disabled status will cause display variable value also in the case of an error status received in the HART frame (the information on the incorrect status is ignore). For DVC the status is always disabled. Detailed description of failure statuses in the Failure symbols for 1HRT module section.

Notes:

The card enables grouping registers, which speeds up data transmission. If the command 03 was selected for several variables read from one device, then during one query the value for the variables PV, TV, SV and FV is got.

11.6.9 OUT6RL - Relay Output Module

Mode: Disabled (Disabled, Normally open, Normally closed, Pulsation)^[1]

- [1]: In the Normally open mode the relay circuit is closed when an event is reported (e.g. exceeded alarm-control threshold). In the Normally closed mode, the relay circuit is normally closed when idle, and is opened when an event is reported. Pulsation - when an event is reported, the relay circuit is closed and opened at approx. 1Hz frequency (e.g. a light indicator blinks - alarm notification). After the acknowledge, the relay output remains active if the threshold is still exceeded (the indicator is lit). If the exceeding returns to normal – the relay output will be inactive.

Notes:

Regardless of the *Mode* selected, after switching off the device and during starting the device, the relay outputs remain open

11.6.10 OUT3 - Analog Output Module

Mode: 0-20mA (Disabled, 0-20mA, 4-20mA, 0-24mA, 0-5V, 0-10V)^[1]

Source: Channel 1 (Channel 1-30)^[2]

Failure value: Constant (Disabled, Constant)^[3]

- [1]: Setting the operating mode of a given output to generate standard loop current signals: 0-20 mA, 4-20 mA, 0-24 mA or standard voltage signals: 0-5 V, 0-10 V, (Disabled sets the output to 0-5 V mode and value 0 V).
- [2]: Selection of the channel which value is to be retransmitted. The output span may be set as a sub-range of retransmitted channel span by entering the process values for minimum and maximum span value respectively.
- [3]: When selection is *Constant*, an additional field will appear allowing user to enter a value. If Disabled mode is selected, the value is set to 0, except for to mode 4-20mA when it is set to 3.6 mA.

11.6.11 PSBATT - Emergency Power Supply Module

In the I/O settings window additional module configuration is not required. The module operating parameters are automatically assigned to subsequent virtual measuring inputs:

1. Battery charge status:

- 1 – low battery level
- 2 – medium battery level
- 3 – high battery level

Note:

The approximate battery charge indicator depends on the load.

2. Operating mode:

- 0 – battery operating (external power supply switched off)
- 1 – pre-charging
- 2 – main charging
- 3 – recharging

3. Voltage (BATT1+BATT2) [V] (approximate value, accuracy $\pm 5\%$)

4. Charging current [A]

5. BATT1 battery temperature [°C]

6. BATT2 battery temperature [°C]

Note:

To display parameters, they must be assigned to channel in the [Channels settings](#) window. After choosing the slot (A, B), choose the input corresponding to one of the parameters listed above

11.6.12 Module M (MAIN)

RL1...RL4

Mode: Disabled (Disabled, Normally open, Normally closed, Pulsation)

Note:

Regardless of the *Mode* selected, after switching off the device and during starting the device, the relay outputs remain open.

OUT (I)

Mode: Disabled (Disabled, 4-20mA)

Source: Channel 1 (Channel 1...Channel 30)^[1]

Failure value: Disabled (Disabled, Constant)^[3]

[1]: Selection one of the channels (selection of any channel from 1 to 30), which value will be retransmitted as 4-20mA current loop signal.

[2]: When selection is *Constant*, an additional field will appear allowing user to enter a value.

11.7 Communication settings

There are two independent hardware communication ports, Ethernet (with RJ45 connector) and serial RS485 port (with A and B terminals). Ethernet port supports Modbus TCP (client and server), WWW server and e-mail notification. RS485 supports Modbus RTU slave communication. Tabs for sub windows Ethernet, E-mail, Modbus TCP and RS485 (COM) are used for all communication settings.

When sensors with Modbus TCP are planned for use, it is recommended to configure Communication before Main Application and Channels configuration.

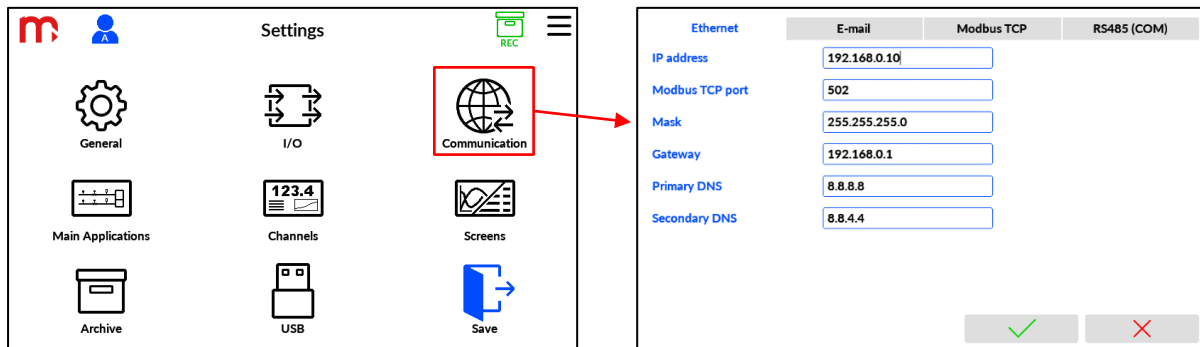

11.7.1 Ethernet

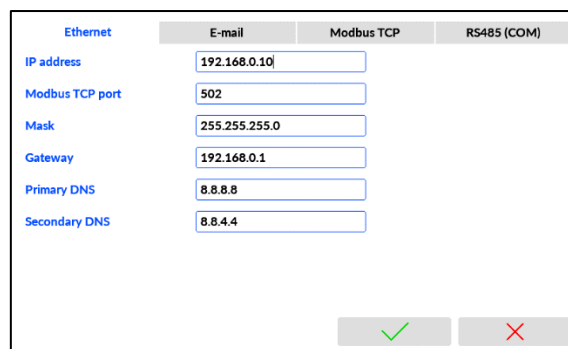

IP Address: [value]^[1]

TCP Modbus Port: [value]^[2]

Mask: [value]^[1]

Gateway: [value]^[1]

Primary DNS: [value]^[3]

Backup DNS: [value]^[3]

[1]: The parameters should be set according to the network to which the device is to be connected.

[2]: It is recommended to use port 502 as dedicated to Modbus TCP. Port 80 is not allowed – it is reserved for the device's web server.

[3]: A DNS address is required when using the E-mail feature. Default DNS server settings: primary address: 8.8.8.8, backup address: 8.8.4.4.

11.7.2 E-mail

The device can send automatic e-mail notifications on alarm statuses and totalizers reports. The process value alarms and set of totalizers for e-mail notification are declared in Channels, for every value individually.

General tab

Email: [value] ^[1]

Login: [value] ^[2]

Password: [value] ^[3]

SMTP server: [value] ^[4]

SMTP Port: [value] ^[5]

[1]: The full address of the email account from which the messages will be sent.

[2]: Login used on the mail server to log in to the e-mail account.

[3]: Password used on the mail server to log in to the e-mail account.

[4]: The address of the SMTP server where the e-mail account is created

[5]: The SMTP server port (without SSL) must be verified with your mail provider (typical 587 or 25).

Note:

The General tab configures the information for the e-mail account from which messages will be sent. The mail account must have the outgoing server (SMTP) enabled. The maximum number of messages sent per day have to be considered and verified with IT service.

Recipients tab

#1: [1st e-mail address] ^[1]

.....
#5: [5th e-mail address] ^[1]

[1]: The recipient's full email address to which the messages is to be sent.

Note:

It is recommended to verify the Connection configuration using the *Test Connection* button. The message appears on the display and the colour indicates the status:

- green - message sent correctly to specified recipients
- yellow - authorization error (check the entered data in the General tab and in the Recipients tab)
- red - connection error (check the Ethernet cable, network connection and IP Address, mask and gateway settings in the Ethernet tab)

The test email contains the model, firmware, serial number, ID number and description of the device. Message subject: *FP40, TEST, ID number, device description*.

The Ethernet parameters must be configured, saved and the device restarted first, before triggering the Test Connection. The device must be connected to the network.

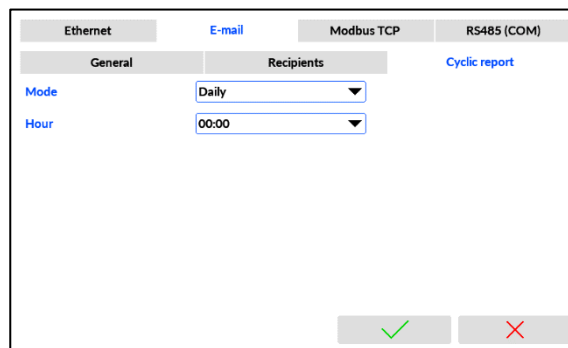
Cyclic Report tab

Mode: Disabled (Disabled, Daily, Weekly, Monthly) ^[1]

Hour: 0 (0:00, ..., 23:00) ^[2]

Day of the week: Sunday (Monday, Tuesday, Wednesday, Thursday, Friday, Saturday, Sunday) ^[3]

Day of the month: 0 (0, ..., 28) ^[4]

[1]: The e-mail messages containing the cyclic report can be sent in the following mode: Daily, Weekly or Monthly.

[2]: The message is sent at the specified full time or each time the device is turned on within the specified hour.

[3]: A day of the week have to be selected. (Only available in Weekly mode.)

[4]: A day of the month have to be selected. (Only available in Monthly mode.)

Note:

The e-mail containing the cyclic report will be sent at the specified time and will contain the values and totalizers units at the time the message is sent (values sent in the form of a table).

11.7.3 Modbus TCP (Client)

The device can read up to 40 values from 20 different devices using the Ethernet connection and Modbus TCP protocol. In order to properly read the data, it is necessary to configure the parameters in the Servers tab and in the Registers tab.

Later on read data is assigned to a process value in Channels (channel type: Remote).

General tab

Failure signalling: Disabled (Disabled, RL1, RL2, RL3, RL4) ^[1]

Message on error: [checkbox] ^[2]

Send email on error: [checkbox] ^[3]

[1]: Data read failure may activate one of the relays RL1, .. RL4. If the failure ceases, then relay returns to its initial state.

[2]: Message on display appears when failure. User acknowledge required.

[3]: E-mail notification is send

Note:

The number of possible e-mails per day should be considered to avoid spam generating. Failure alerts may appear very frequently in some applications.

Servers tab

Mode	IP address	Timeout [ms]	Read interval [s]
Disabled	192.168.0.11:502	5000	2
Disabled	192.168.0.11:502	5000	2
Disabled	192.168.0.11:502	5000	2
Disabled	192.168.0.11:502	5000	2
Disabled	192.168.0.11:502	5000	2
Disabled	192.168.0.11:502	5000	2
Disabled	192.168.0.11:502	5000	2
Disabled	192.168.0.11:502	5000	2
Disabled	192.168.0.11:502	5000	2

Mode: Disabled (Disabled, Enabled) ^[1]

IP Address: [IP address value] ^[2]

Port: [value] ^[3]

Read Interval: [value] s (1, .., 3600) ^[4]

Timeout: [value] ms (1000, .., 60000) ^[5]

[1]: Activates the server address. Up to 20 independent servers/connections are possible. If the sensor or device (slave) connected to the server is disconnected, it is

recommended to turn off the server to avoid timeout. (The change in the Channels settings and from the Registers tab is not required).

- [2]: The IP address uniquely identifies the server. The entered data is displayed in the format IP Address: Port, e.g.192.168.2.15:502.
- [3]: It is recommended to set port 502 as dedicated to Modbus TCP. Port 80 is not allowed – it is reserved for the device's web server.
- [4]: Time between queries to the specified server.
- [5]: Timeout for response.

Registers tab

Ethernet		E-mail		Modbus TCP		RS485 (COM)	
General		Servers		Registers			
#	Server	Device	Register	Type			
1	Disabled	1	300000	uint (16bit)			
2	Disabled	1	300000	uint (16bit)			
3	Disabled	1	300000	uint (16bit)			
4	Disabled	1	300000	uint (16bit)			
5	Disabled	1	300000	uint (16bit)			
6	Disabled	1	300000	uint (16bit)			
7	Disabled	1	300000	uint (16bit)			
8	Disabled	1	300000	uint (16bit)			

#: 1 (1, .., 20)^[1]

Server: Disabled (Disabled, select from the list of added servers)^[2]

Device: [device address] (1, .., 247)^[3]

Address: [address of the register]^[4]

Type: uint(16bit) (uint (16bit), int (16bit), uint (32bit), uint (32bit) sw, int (32bit), int (32bit) sw, float (32bit), float (32bit) sw, int (64bit), double (64bit))^[5]

- [1]: Number, number from 1 to 20. If several sensors are connected to a single server, the query to the sensors is sent in the order of the number.
- [2]: Select from the list of added servers (configuration in the Servers tab). You can assign a server to the registry in Disabled mode.
- [3]: Modbus RTU address of the sensor or device (slave device).
- [4]: Set the registry number of the device from which data will be read. Available format 3xxxx / 3xxxxx or 4xxxx / 4xxxxx, where: 3 – Input register, 4 – Holding register, xxxx / xxxxx – four-digit / five-digit address. The value must be specified in the decimal system. More information in the chapter [MODBUS RTU / MODBUS TCP TRANSMISSION PROTOCOL](#).
- [5]: Ten formats of readings are available in the drop-down list, where: uint – unsigned integer, int – signed integer, float – single precision floating point, double – double precision floating point, sw – swapped format (more information in section [Data types](#)). Choose a format that matches the specification of the sensor or device you are reading.

Notes:

It is possible to group registers to optimize the data transmission. If the register address is the next value to the sum of the previous address and the type size of the preceding register, the registers will be grouped into one query.

11.7.4 RS485 (COM)

Ethernet	E-mail	Modbus TCP	RS485 (COM)
			Baud Rate
			19200
			Parity
			None
			Modbus RTU Address
			1
			<input type="button" value="✓"/> <input type="button" value="✗"/>

Baud Rate: 19200 (2400, 4800, 9600, 19200, 38400, 57600, 115200) ^[1]

Parity: NONE (NONE, EVEN, ODD) ^[2]

Modbus RTU address: [machine address] (1, ..., 247) ^[3]

[1]: In the case of long distances or high levels of interference, it may be necessary to reduce the speed. Low transmission speed increases data transmission time.

[2]: Parity control setting.

[3]: The address must be unique within one RS485 network.

Note:

The RS485 port settings of the machine must match those of the master. More information about data types, registers and Modbus addresses in the chapter [MODBUS RTU / MODBUS TCP TRANSMISSION PROTOCOL](#).

11.8 Main Application settings

The Flow computer performs measurements and calculations for two independent measurement applications A and B. Both measuring applications are configured in the window, switching between sub windows using tabs A and B.

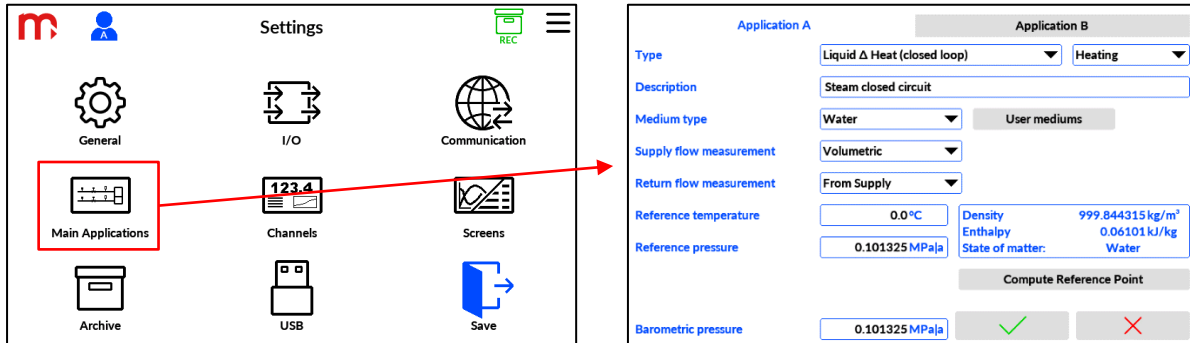

First application type have to be selected. The content of the application settings window varies depending on the selected application type. By default, both measuring systems (A and B) are disabled.

11.8.1 Liquid Flow

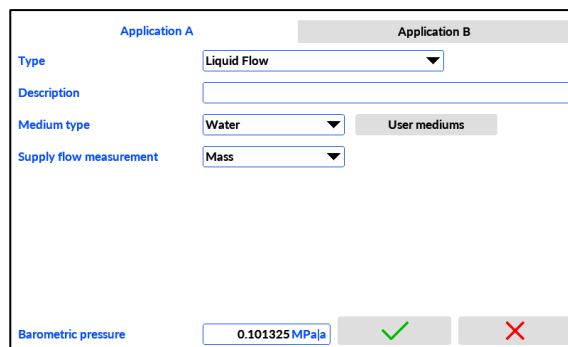

Type: Liquid Flow

Description: [text]^[1]

Medium Type: Water (Water, User Medium)^[2]

Supply Flow Measurement: Mass (Mass, Volumetric, Orifice)^[3]

Barometric pressure [MPa[a]: [value]^[4]

[1]: User's entered text string for application identification. This description is displayed in the Application Main Screen, in the Application Table and in the drop-down menu. The description can be up to 20 characters long.

[2]: To change medium type user have to download density table. More details in chapter [User Medium](#).

[3]: For orifice working with user medium, an extra information have to be entered. More details in chapter [Differential pressure flow meters](#).

[4]: The value of the average atmospheric absolute pressure in the area.

Note:

Button *Compute Reference Point* allows user to verify the value of density for chosen pressure and temperature values. In this application reference points are not used.

Application A	Application B
Type	Liquid Heat
Description	
Medium type	Water User mediums
Supply flow measurement	Mass
Reference temperature	0.0°C
Reference pressure	0.101325 MPa _a
	Density 999.844315 kg/m ³ Enthalpy 0.06101kJ/kg State of matter: Water
	Compute Reference Point
Barometric pressure	0.101325 MPa _a ✓ ✗

11.8.2 Liquid Heat

Type: Liquid Heat

Description: [text]^[1]

Medium Type: Water (Water, User Medium)^[2]

Supply Flow Measurement: Mass (Mass, Volumetric, Orifice)^[3]

Reference temperature [°C]: [value]^[4]

Reference pressure [MPa_a]: [value]^[4]

Barometric pressure [MPa_a]: [value]^[5]

[1]: User's entered text string for application identification. This description is displayed in the Application Main Screen, in the Application Table and in the drop-down menu. The description can be up to 20 characters long.

[2]: To change medium type user have to download density and enthalpy tables. More details in chapter [User Medium](#).

[3]: For orifice working with user medium, an extra information have to be entered. More details in chapter [Differential pressure flow meters](#).

[4]: Reference temperature and pressure is used to define the enthalpy level above which the liquid heat is calculated. For water, the reference enthalpy is calculated from build-in tables. For other medium it is calculated from user table.

[5]: The value of the average atmospheric absolute pressure in the area (default 0.101325 MPa_a). This value is used to convert gauge and absolute pressure.

Note:

If the application uses user medium with specific heat, the energy is calculated as a difference between reference point and actual measured point.

Button *Compute Reference Point* allows user to verify the value of enthalpy and density for chosen pressure and temperature values.

11.8.3 Liquid delta Heat (Closed loop)

Application A	Application B
Type	Liquid Δ Heat (closed loop) Heating
Description	
Medium type	Water User mediums
Supply flow measurement	Mass
Return flow measurement	From Supply
Reference temperature	0.0°C Density 999.844315 kg/m ³
Reference pressure	0.101325 MPa _a Enthalpy 0.06101 kJ/kg
	State of matter: Water
	Compute Reference Point
Barometric pressure	0.101325 MPa _a ✓ ✗

Type: Liquid Δ Heat (closed loop) ^[1]

Description: [text] ^[2]

Medium Type: Water (Water, User Medium) ^[3]

Supply Flow Measurement: Mass (Mass, Volumetric, Orifice^[5], From Return) ^[4]

Return Flow Measurement: Mass (Mass, Volumetric, Orifice^[5], From Supply) ^[4]

Reference temperature [°C]: [value] ^[6]

Reference pressure [MPa_a]: [value] ^[6]

Barometric pressure [MPa_a]: [value] ^[7]

[1]: For *Liquid delta Heat (closed loop)* application it is possible to choose between heating or cooling mode. In the cooling application, the heat received from the system is calculated. In the heating application, the heat supplied to the system is calculated.

[2]: User's entered text string for application identification. This description is displayed in the Application Main Screen, in the Application Table and in the drop-down menu. The description can be up to 20 characters long.

[3]: To change medium type user have to download density and enthalpy tables. More details in chapter [User Medium](#).

[4]: In this application only one flow meter is used. The second one is taken into calculation as a mass flowrate, after flow compensation calculations.

[5]: For orifice working with user medium, an extra information have to be entered. More details in chapter [Differential pressure flow meters](#).

[6]: Reference temperature and pressure is used to define the enthalpy level above which the liquid heat is calculated. For water, the reference enthalpy is calculated from build-in tables. For other medium it is calculated from user table.

[7]: The value of the average atmospheric absolute pressure in the area. This value is used to convert gauge and absolute pressure.

Note:

If User Table uses specific heat as a function of temperature, then for energy calculation the average value of specific heat at supply and return is taken. Supply and return energy will not be displayed.

Button *Compute Reference Point* allows user to verify the value of enthalpy and density for chosen pressure and temperature values.

11.8.4 Liquid delta Heat

Application A	Application B
Type	Liquid Δ Heat Heating
Description	
Medium type	Water User mediums
Supply flow measurement	Mass
Return flow measurement	Mass
Reference temperature	0.0°C Density 999.844315 kg/m ³
Reference pressure	0.101325 MPa _a Enthalpy 0.06101 kJ/kg
	State of matter: Water
	Compute Reference Point
Barometric pressure	0.101325 MPa _a ✓ ✗

Type: Liquid Δ Heat^[1]

Description: [text]^[2]

Medium Type: Water (Water, User Medium)^[3]

Supply Flow Measurement: Mass (Mass, Volumetric, Orifice^[5], From Return)^[4]

Return Flow Measurement: Mass (Mass, Volumetric, Orifice^[5], From Supply)^[4]

Reference temperature [°C]: [value]^[6]

Reference pressure [MPa_a]: [value]^[6]

Barometric pressure [MPa_a]: [value]^[7]

- [1]: For *Liquid delta Heat* application it is possible to choose between heating or cooling mode. In the cooling application, the heat received from the system is calculated. In the heating application, the heat supplied to the system is calculated.
- [2]: User's entered text string for application identification. This description is displayed in the Application Main Screen, in the Application Table and in the drop-down menu. The description can be up to 20 characters long.
- [3]: To change medium type user have to download density and enthalpy tables. More details in chapter [User Medium](#).
- [4]: In this application two flow meters are used, separately for supply and return pipeline.
- [5]: For orifice working with user medium, an extra information have to be entered. More details in chapter [Differential pressure flow meters](#).
- [6]: Reference temperature and pressure is used to define the enthalpy level above which the liquid heat is calculated. For water, the reference enthalpy is calculated from build-in tables. For other medium it is calculated from user table.
- [7]: The value of the average atmospheric absolute pressure in the area. This value is used to convert gauge and absolute pressure.

Note:

If User Table uses specific heat as a function of temperature, then for energy calculation the average value of specific heat at supply and return is taken. Supply and return energy will not be displayed.

Button *Compute Reference Point* allows user to verify the value of enthalpy and density for chosen pressure and temperature values.

11.8.5 Steam net Heat

Application A	Application B
Type	Steam net heat
Description	
Steam type	Superheated
Supply flow measurement	Mass
Reference temperature	0.0°C
Reference pressure	0.101325 MPa _a
Density	999.844315 kg/m ³
Enthalpy	0.06101 kJ/kg
State of matter:	Water
Compute Reference Point	
Barometric pressure	0.101325 MPa _a <input checked="" type="checkbox"/> <input type="checkbox"/>

Type: Steam net Heat

Description: [text]^[1]

Steam Type: Superheated (Saturated p(T), Saturated T(p))^[2]

Steam Dryness [%]: 100 [value]^[3]

Supply Flow Measurement: Mass (Mass, Volumetric, Orifice)

Reference temperature [°C]: [value]^[4]

Reference pressure [MPa_a]: [value]^[4]

Barometric pressure [MPa_a]: [value]^[5]

- [1]: User's entered text string for application identification. This description is displayed in the Application Main Screen, in the Application Table and in the drop-down menu. The description can be up to 20 characters long.
- [2]: Superheated steam measurement requires both, pressure and temperature measurements. Saturated steam use only one measurement, temperature or pressure. Second value is calculate from build in saturation curve.
- [3]: Dryness of steam may be entered for saturated steam. Typically it is in range 80 .. 100%. 100% means completely dry. This parameter is not applicable and is hidden for superheated steam.
- [4]: Reference temperature and pressure is used to define the enthalpy level above which the heat is calculated.
- [5]: The value of the average atmospheric absolute pressure in the area. This value is used to convert gauge and absolute pressure.

Note:

Button *Compute Reference Point* allows user to verify the value of enthalpy and density for chosen pressure and temperature values.

11.8.6 Steam – Condensate Δ Heat (Closed loop)

Application A	Application B
Type	Steam-Cond. Δ Heat (closed loop)
Description	
Steam type	Superheated
Supply flow measurement	Mass
Return flow measurement	From Supply
Reference temperature	0.0°C
Reference pressure	0.101325 MPa _a
Barometric pressure	0.101325 MPa _a
	Density: 999.844315 kg/m ³ Enthalpy: 0.06101kJ/kg State of matter: Water
	<input type="button" value="Compute Reference Point"/> <input checked="" type="button" value="✓"/> <input type="button" value="✗"/>

Type: Steam-Cond. Δ Heat (closed loop)

Description: [text]^[1]

Steam Type: Superheated (Saturated p(T), Saturated T(p))^[2]

Steam Dryness [%]: 100 [value]^[3]

Supply Flow Measurement: Mass (Mass, Volumetric, Orifice, From Return)^[4]

Return Flow Measurement: Mass (Mass, Volumetric, Orifice, From Supply)^[4]

Reference temperature [°C]: [value]^[5]

Reference pressure [MPa_a]: [value]^[5]

Barometric pressure [MPa_a]: [value]^[6]

- [1]: User's entered text string for application identification. This description is displayed in the Application Main Screen, in the Application Table and in the drop-down menu. The description can be up to 20 characters long.
- [2]: Superheated steam measurement requires both, pressure and temperature measurements. Saturated steam use only one measurement, temperature or pressure. Second value is calculate from build in saturation curve.
- [3]: Dryness of steam may be entered for saturated steam. Typically it is in range 80 .. 100%. 100% means completely dry steam. This parameter is not applicable and is hidden for superheated steam.
- [4]: In this application only one flow meter is used. The second one is taken into calculation as a mass flowrate, after flow compensation calculations.
- [5]: Reference temperature and pressure is used to define the enthalpy level above which the heat is calculated.
- [6]: The value of the average atmospheric absolute pressure in the area. This value is used to convert gauge and absolute pressure.

Note:

For condensate both, temperature and pressure may be measured. If only one of them is measured, typically temperature, then the other one should be entered as a constant value. In some application both may be entered as constant value. (It is configured in Channels settings.)

Button *Compute Reference Point* allows user to verify the value of enthalpy and density for chosen pressure and temperature values.

11.8.7 Steam – Condensate Δ Heat

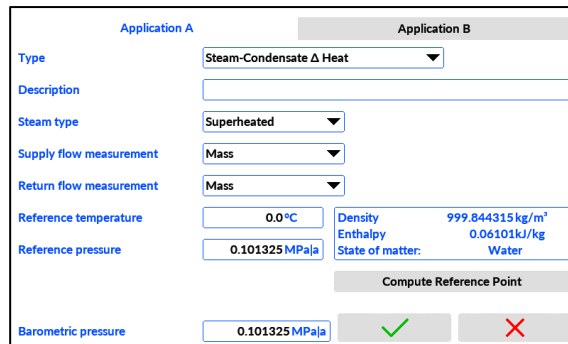

Type: Steam-Cond. Δ Heat

Description: [text]^[1]

Steam Type: Superheated (Saturated p(T), Saturated T(p))^[2]

Steam Dryness [%]: 100 [value]^[3]

Supply Flow Measurement: Mass (Mass, Volumetric, Orifice)

Return Flow Measurement: Mass (Mass, Volumetric, Orifice)

Reference temperature [°C]: [value]^[4]

Reference pressure [MPa|a]: [value]^[4]

Barometric pressure [MPa|a]: [value]^[5]

- [1]: User's entered text string for application identification. This description is displayed in the Application Main Screen, in the Application Table and in the drop-down menu. The description can be up to 20 characters long.
- [2]: Superheated steam measurement requires both, pressure and temperature measurements. Saturated steam use only one measurement, temperature or pressure. Second value is calculate from build in saturation curve.
- [3]: Dryness of steam may be entered for saturated steam. Typically it is in range 80 .. 100%. 100% means completely dry. This parameter is not applicable and is hidden for superheated steam.
- [4]: Reference temperature and pressure is used to define the enthalpy level above which the heat is calculated.
- [5]: The value of the average atmospheric absolute pressure in the area. This value is used to convert gauge and absolute pressure.

Note:

For condensate both, temperature and pressure may be measured. If only one of them is measured, typically temperature, then the other one should be entered as a constant value. In some application both may be entered as constant value. (It is configured in Channels settings.)

Button *Compute Reference Point* allows user to verify the value of enthalpy and density for chosen pressure and temperature values.

11.8.8 Steam generator

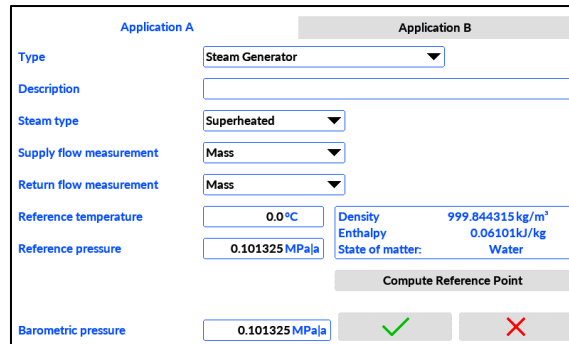

Type: Steam Generator

Description: [text]^[1]

Steam Type: Superheated (Saturated p(T), Saturated T(p))^[2]

Steam Dryness [%]: 100 [value]^[3]

Supply Flow Measurement: Mass (Mass, Volumetric, Orifice^[5])^[4]

Return Flow Measurement: Mass (Mass, Volumetric, Orifice^[5])^[4]

Reference temperature [°C]: [value]^[6]

Reference pressure [MPa(a)]: [value]^[6]

Barometric pressure [MPa(a)]: [value]^[7]

- [1]: User's entered text string for application identification. This description is displayed in the Application Main Screen, in the Application Table and in the drop-down menu. The description can be up to 20 characters long.
- [2]: Superheated steam measurement requires both, pressure and temperature measurements. Saturated steam use only one measurement, temperature or pressure. Second value is calculate from build in saturation curve.
- [3]: Dryness of steam may be entered for saturated steam. Typically it is in range 80 .. 100%. 100% means completely dry. This parameter is not applicable and is hidden for superheated steam.
- [4]: In this application one or two flow meters may be used. If one flow meter is used, then the second flowrate is taken into calculation as a mass flowrate, from the first one.
- [5]: Reference temperature and pressure is used to define the enthalpy level above which the heat is calculated.
- [6]: The value of the average atmospheric absolute pressure in the area. This value is used to convert gauge and absolute pressure.

Note:

For water supply both, temperature and pressure may be measured. If only one of them is measured, typically temperature, then the other one should be entered as a constant value. In some application both may be entered as constant value. (It is configured in Channels settings.)

Button *Compute Reference Point* allows user to verify the value of enthalpy and density for chosen pressure and temperature values.

11.8.9 Gas Flow

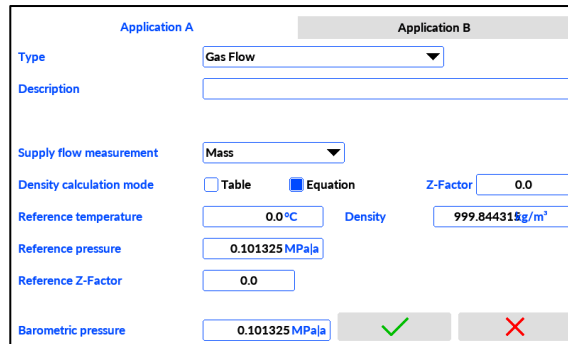

Type: Gas Flow

Description: [text]^[1]

Medium type: [user tables list]^{[2][4]}

Supply Flow Measurement: Mass (Mass, Volumetric, Orifice^[3], Normalized vol.)

Density calculation mode: Table / Equation (checkbox)^[6]

Z-Factor: [value]^[5]

Reference temperature [°C]: [value]

Reference pressure [MPa(a)]: [value]

Density [kg/m³]: [value]

Reference Z-Factor: [value]^[5]

Barometric pressure [MPa(a)]: [value]^[7]

- [1]: User's entered text string for application identification. This description is displayed in the *Application Main Screen*, in the *Application Table* and in the drop-down menu. The description can be up to 20 characters long.
- [2]: Medium type allows to choose the User Medium table using User Mediums button. More details in chapter [User Medium](#).
- [3]: For orifice, an extra information have to be entered. More details in chapter [Differential pressure flow meters](#)
- [4]: This parameter is not applicable and is hidden when *Density calculation mode* is set to *Equation*.
- [5]: This parameter is not applicable and is hidden when *Density calculation mode* is set to *Table*.
- [6]: Mode set to *Equation* means that density calculations are processed according to ideal gas equation relative to reference pressure and temperature. Mode set to *Table* means that density is get from user medium table.
- [7]: The value of the average atmospheric absolute pressure in the area. This value is used to convert gauge and absolute pressure.

Note:

Z-factor is entered as a constant value for the gas at average working conditions of temperature and pressure. If the value is not known, it is best to enter 1.0.

If *Density calculation mode* is set to *Table*, pressing the button *Compute Reference Point* will calculate density at reference points.

11.8.10 Gas Heat

Type: Gas Heat

Description: [text]^[1]

Medium type: [user tables list]^{[2][3]}

Supply Flow Measurement: Mass (Mass, Volumetric, Orifice^[4], Normalized vol.)

Density calculation mode: Table / Equation (checkbox)^[5]

Z-Factor: [value]^[6]

Reference temperature [°C]: [value]

Reference pressure [MPa(a)]: [value]

Density [kg/m³]: [value]

Reference Z-Factor: [value]^[6]

Barometric pressure [MPa(a)]: [value]^[7]

- [1]: User's entered text string for application identification. This description is displayed in the Application Main Screen, in the Application Table and in the drop-down menu. The description can be up to 20 characters long.
- [2]: Medium type allows to choose the User Medium table using User Mediums button. More details in chapter [User Medium](#).
- [3]: Gas heat application always use medium table to calculate enthalpy, specific heat or calorific of the gas.
- [4]: For orifice, an extra information have to be entered. More details in chapter [Differential pressure flow meters](#).
- [5]: Mode set to *Equation* means that density calculations are processed according to ideal gas equation relative to reference pressure and temperature. Mode set to *Table* means that density is get from user medium table
- [6]: This parameter is not applicable and is hidden when Density calculation mode is set to Table.
- [7]: The value of the average atmospheric absolute pressure in the area. This value is used to convert gauge and absolute pressure.

Note:

Z-factor is entered as a constant value for the gas at average working conditions of temperature and pressure. If the value is not known, it is best to enter 1.0.

If *Density calculation mode* is set to *Equation*, pressing the button *Compute Reference Point* will calculate enthalpy and density at reference points. If it is set to *Table* only enthalpy is calculated.

11.8.11 Mass flow measurement

In this case mass flow is measured. Value can be taken form:

- measurement cards (analogue inputs, discrete inputs, Modbus RTU or HART)
- constant value defined by user
- remote (Modbus TCP)
- computed with user formula (e.g. sum of two channels)

Volumetric flow, normalized volumetric flow (only for gas applications) will be calculated using density and mass flow. Detailed configuration is entered in [Channels settings](#).

11.8.12 Volumetric flowmeters

In this case volumetric flow is measured. Value can be taken form:

- measurement cards (analogue inputs, discrete inputs, Modbus RTU or HART)
- constant value defined by user
- remote (Modbus TCP)
- computed with user formula (e.g. sum of two channels)

Mass flow, normalized volumetric flow (only for gas applications) will be calculated using density and volumetric flow. Detailed configuration is entered in [Channels settings](#).

11.8.13 Normalized volumetric flowmeters

In this case normalized volumetric flow is measured. Value can be taken form:

- measurement cards (analogue inputs, discrete inputs, Modbus RTU or HART)
- constant value defined by user
- remote (Modbus TCP)
- computed with user formula (e.g. sum of two channels)

Mass flow, volumetric flow (only for gas applications) will be calculated using density and volumetric flow. Detailed configuration is entered in [Channels settings](#).

11.8.14 Differential pressure flowmeters

In this case differential pressure is measured value can be taken form:

- measurement cards (analogue inputs, discrete inputs, Modbus RTU or HART)
- constant value defined by user
- remote (Modbus TCP)
- computed with user formula (e.g. sum of two channels)

Mass flow will be calculated due to selected Orifice type. When *Orifice* flow meter is chosen in *Main Application* settings window, then on the right side will appears button *Set Orifice*. Tapping it will open a new window with required settings to be entered. At first, the user should select the orifice type:

- Square root approximation
- Flange tappings (EN ISO 5167)
- D-D/2 pressure tappings (EN ISO 5167)
- Corner tappings (EN ISO 5167)
- ISA1932 nozzle (EN ISO 5167)
- Long radius nozzle (EN ISO 5167)
- Venturi nozzle (EN ISO 5167)
- Venturi tube – cast (EN ISO 5167)
- Venturi tube – machined (EN ISO 5167)

- Venturi tube – rough welded sheet-iron (EN ISO 5167)
- Micro orifice for corner tap configuration (ASME MFC-14M)
- Micro orifice for flange tap configuration (ASME MFC-14M)
- ILVA, Gilflo B, Gilflo SPOOL (Spirax Sarco Ltd.)

11.8.14.1 The Square Root Approximation

The Square Root Approximation requires only three parameters to be entered as nominal values (working point or close to working point of orifice): Δp_0 , ρ_0 , q_{m0} and X

Δp_0 - is nominal value of differential pressure for orifice.

ρ_0 - is nominal density of gas or liquid. It have to be calculated or may be obtained main application screen at reference values of pressure and/or temperature.

q_{m0} - is mass flowrate at Δp_0 and ρ_0

User correction - user arbitrary flow correction factor. In most applications is set to 1.000.

The main screen Reference Point calculator may be used to calculate the density required for orifice ρ_0 nominal density, but after that it must return back to reference point values. The reference point is required for other calculations, and should not be not confused with the nominal parameters for orifice.

The square root approximation calculates mass flowrate corrected to pressure and/or temperature at working conditions. The square root approximation is not as accurate as other differential pressure measurements.

11.8.14.2 Differential flowmeters compatible with EN ISO 5167 or ASME MFC-14M

The dp flow meters according to EN ISO 5167 or ASME MFC-14M require entering pipeline and orifice parameters: D0, d0, α D, α d and X

D0 - internal pipeline diameter

d0 - orifice bore diameter

α D - thermal expansion coefficient of the pipeline material

α d - thermal expansion coefficient of the orifice material

User correction - user arbitrary flow correction factor. In most applications is set to 1.000.

All additional required parameters for steam and water are build-in in the device. For other mediums the dynamic viscosity of the fluid is taken from [User Medium](#) table.

Limitations:

- According to the norms, all orifice type devices have limit for minimum and maximum D and d values, as well as for ratio d/D. For some very special applications that limits are not implemented in device. It is strongly recommended to enter orifice parameters based on orifice project documentation prepared by flowmeter designer, where all parameters, limits and accuracy considerations are taken into account.
- For other fluids than steam and water the dynamic viscosity is used as a constant value and should be entered as an average value close to working conditions of pressure and temperature. (For some fluids dynamic viscosity may strongly depend on temperature.)
- For technical gases isentropic exponent is assumed constant and equal to 1.3. This value variation have minor influence on accuracy of typical industrial applications.

The ILVA / GILFLO flow meters require entering water calibration table delivered by flowmeter manufacturer and choosing the flowmeter size.

The calibration table may also be imported as a .csv type file.

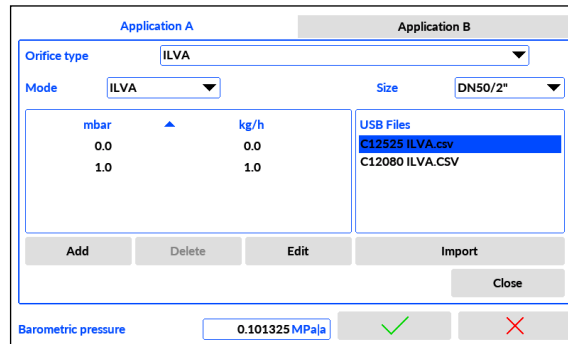

More details on preparing the table in chapter [Ilva / Gilflo calibration table](#).

11.9 Channels settings

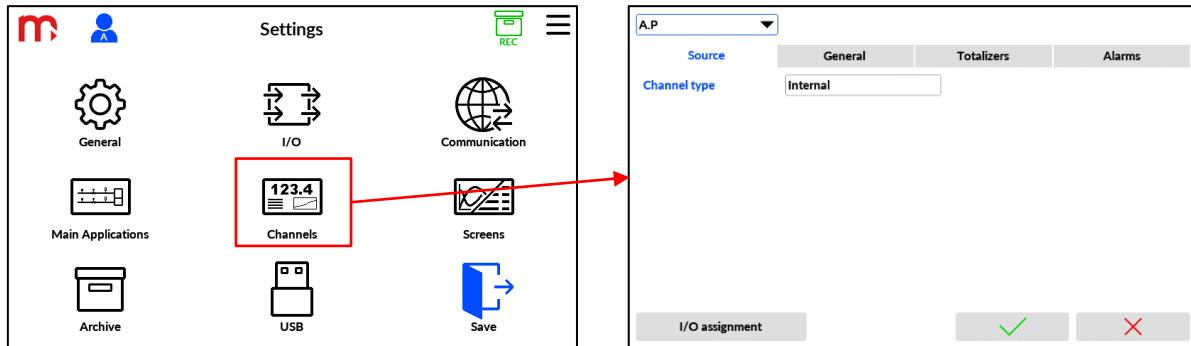

In the *Channels* settings window all process values parameters like units, resolution, alarms, related totalizers, measuring inputs assignments, etc., are configured. All possible channels are listed in drop down menu.

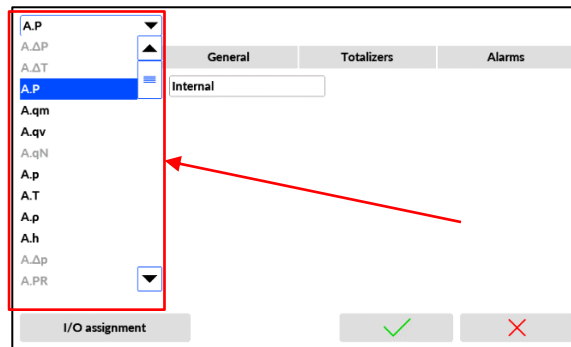

Channels disabled for chosen application are dimmed automatically and are not accessed for configuration. Available channels are activated during *Main Applications* configuration process. Channels for auxiliary application X are always available. All parameters are grouped and configured in sub windows and are accessed by tapping *Source*, *General*, *Totalizers* and *Alarms* tabs. As a help during configuration process, I/O assignment may be verified by tapping *I/O assignment* button.

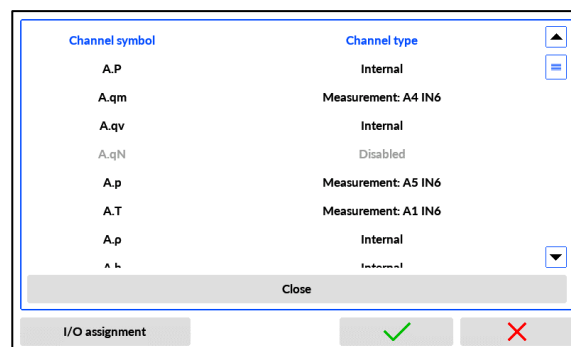

11.9.1 Input data source

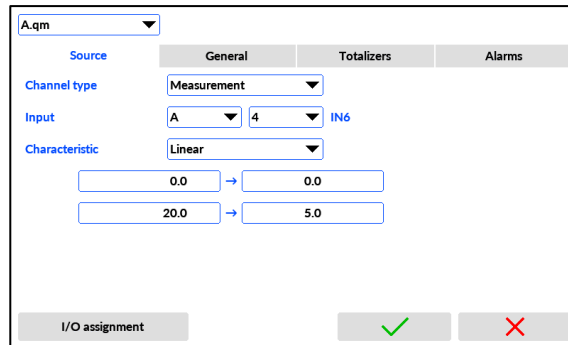

Source: Disabled (Disabled, Internal, Measurement, Constant, Remote, Computed) ^[1]

Input: A(A, B, M), 1 (1...25) ^{[2][3]}

Value: [value]

Register: 1. (1...40) ^[4]

Formula: [entered math formula] ^[6]

Characteristic: Linear (Linear, User, 1:1, depending on the type of input) ^[6]

[1]: Selecting the source of the channel value. The selection activates other settings displayed in this tab. Channels from application A and B which are calculate are set as *Internal*. Their type cannot be changed or disabled. Others channels can be configure as *Measurement*, *Constant*, *Remote* or *Computed*. In *Measurement* value is taken form measurement card input/output. *Constant* is used intentionally for the application (e.g. constant pressure) or temporary (e.g. when sensor is damaged or for test purpose). In *Remote* value is taken form build in Modbus TCP Client. Computed allow user to define own formula (More information in chapter [Computed channels](#))

[2]: Available only when selected *Source* is *Measurement*

[3]: Number of inputs depends on card type

[4]: Selecting one of defined Modbus TCP registers. (Configured earlier in [Modbus TCP \(Client\)](#).)

[5]: Allows to enter user math formula. (More in chapter [Computed channels](#))

[6]: Available characteristics depends on chosen *Source* and card Type. For cards IN3T and IN6T user can choose additional RTD or TC sensor characteristic. For cards IN3D and IN6D characteristics depends on input settings. For *State* mode user can only assignment value for 0 and 1 state. For *Pulse Counter* mode user can only assign a weight to the appropriate number of pulses. For frequency mode there available standard characteristics.

11.9.2 General

Description: [text]^[1]

Unit: [] (list of available units for channel, option to add a user unit)^[2]

Filter: Off (Off, 2 s, 5 s, 10 s, 20 s, 30 s, 1 min, 2 min, 3 min, 5 min)^[3]

Resolution: 0.00 (0, 0.0, 0.00, 0.000, 0.0000)^[4]

Failure value: Off (Off, On)^[5]

Cutoff: Off (Off, On)^[6]

Cutoff level: [value]^[6]

Archiving: Off (Off, On)^[7]

Trend min: [value]^[8]

Trend max: [value]^[8]

- [1]: User's entered text for application identification, max 20 character. This description is displayed in the Single Result Window, in User Tables, in User Trends and is saved in archival files.
- [2]: For channels from application A and B, available list of units is determined by the channel type (temperature measurement, enthalpy etc.). For channels in the X, all units are available. In special cases, it is possible to define new user unit, using button *User unit*. (More in chapter [User Unit](#).)
- [3]: For input channels it is possible to set a low pass filter. It allows to "smooth" sudden jumps of the measured value or eliminate background measurement noise. Too high value may distort the shape of real changes of result. This option is disabled for *Internal* channels.
- [4]: The resolution determines the number of decimal places in the displayed result.
- [5]: For input channels a failure value may be activated. The failure value is a fixed value displayed instead of the measurement result, in the event of an input signal failure or when the calculation result is out of range. After enabling this option, an additional field will appear allowing user to enter a value. This option is disabled for Internal channels.
- [6]: Enabling the cut-off function forces value 0 if the channel value measured or calculated is less than the entered level. After enabling this option, an additional field will appear allowing user to enter a value.
- [7]: Enables or disables archiving of a given channel. Enabling is equivalent to adding a channel to archiving.
- [8]: Sets the range of the displayed trend chart in the Single Result Window. If the chart is not set correctly, the trend line may not be visible (be out of scale).

11.9.3 Totalizers

Type: Disabled (Disabled, Non-resettable, Resetable, Daily, Weekly, Monthly) ^[1]

Unit: [] (list of available units, option to add a user unit) ^[2]

Resolution: 0.00 (0, 0.0, 0.00, 0.000, 0.0000) ^[3]

Archiving: Off (Off, On) ^[4]

Email: Off (Off, On) ^[5]

[1]: Each totalizer can be set in one of six modes: Disabled (no totalizer), Non resettable (user is not able to reset the totalizer), Resetable (user can reset totalizer on request at any time), Daily (reset automatically at midnight), Weekly (reset automatically at midnight from Sunday to Monday), Monthly (reset automatically at midnight during the month change).

[2]: For channels from application A and B, available list of units is determined by the channel type (volumetric flow, power etc.). For channels in the X, all units are available. In special cases, it is possible to define new user unit, using button *User unit*. (More in chapter [User Unit](#).)

[3]: The resolution determines the number of decimal places in the displayed result.

[4]: Enables/disables totalizer archiving. Enabling is equivalent to adding the totalizer to archiving.

[5]: Add the totalizer to the list for the cyclic e-mail report (More information in chapter [E-mail](#)).

11.9.4 Alarms

Type: Disabled (disabled, High, Low) ^[1]

Mode: Alarm (Alarm, Control) ^[2]

Level: [value] ^[3]

Hysteresis: [value] ^[4]



Color: Off (Disabled, Green, Orange, Red) ^[5]

Output: Off (Disabled, Enabled) ^[6]

Log event: Off (Off, On) ^[7]

Change the frequency of archiving: Off (Off, On) ^[8]

Email notification: Off (Off, On) ^[9]

- [1]: The alarm type can be set to High (active above the level value) or Low (active below the level value).
- [2]: The mode Alarm (latched type) when activated display alert, pulsing alarm pictogram  and beeper signal. Alert is active even the source of alarm returned to normal value. It requires acknowledge by the user on the front panel. The mode Control is active as long as the alarm level is exceeded. There is no extra alert on the display. But the status may be checked in the Alarm status screen, by tapping the pictogram .
- [3]: The value of the alarm threshold level is entered in units of measured process value for the channel. Level is displayed as a horizontal dotted line in the Single Channel window, on the trend.
- [4]: The hysteresis value is the difference between the level of threshold crossing and return. The value is entered in units of measured process value for the channel.
- [5]: The process value digits may change colour when alarm is active. There are three alarm colours: *Green*, *Orange*, and *Red*.
- [6]: Card output assigned to alarm. After enabling additional fields will appear for selection slot and output. It will only work with OUT6RL card and relay output on MAIN card
- [7]: Alarm events may be logged in the Event ARCHIVE when enabled.
- [8]: There are two speeds of archiving data available. Activated alarm may switch Main Archive Interval from level I to level II.
- [9]: Alarms may cause sending an e-mail message. (More information how in chapter E-mail).

NOTE:

The number of possible e-mails per day should be considered to avoid spam generating. Alarm alerts may appear very frequently in some applications.

11.10 Screen settings

In the user screen settings it is possible to configure values from different applications. Up to 6 user tables and up to 6 user trends can be configured. User tables allow displaying up to 16 results. It is possible to display process values, minimum, maximum and counters. User trends allow displaying up to 6 results on one graph. It is possible to add only process values.

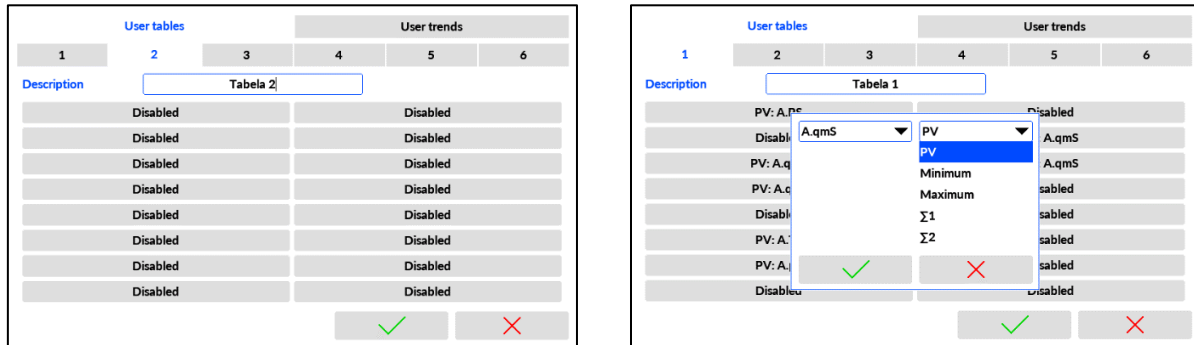

11.10.1 User tables

Tabs: 1 (1, 2, 3, 4, 5, 6) ^[1]

Description: [text] ^[2]

Table cell: Disabled (Disabled, channel symbol and value type: PV, MIN, MAX, Σ1, Σ2) ^[3]

[1]: Selects the table that to be modified.

[2]: Each table screen can be given unique name up to 20 characters long.

[3]: The window contains a 16-element table (2x8 layout). Values can be changed by tapping table cell. The editing window contains two drop-down selection lists: to select a channel and the type of presented value: PV – process value, MIN – minimum value, MAX – maximum value, Σ1 – totalizer 1 and Σ2 – totalizer 2. (In the device, the minimum value is also marked as ▼, and maximum as: ▲.)

NOTE:

If all cells are disabled, the table will not be available in the User Tables screen.

11.10.2 User trends

Tab: 1 (1, 2, 3, 4, 5, 6) ^[1]

Description: [text] ^[2]

Minimum: [value] ^[3]

Maximum: [value] ^[3]

Chart element: Disabled (Disabled, channel symbol selection) ^[4]

[1]: Selects the trend screen to be modify.

[2]: Each trend screen can be given a unique name up to 20 characters long.

[3]: Sets the range of the displayed chart. Each trend screen may have different range.
The time scale is fixed.

[4]: For each trend screens it is possible to program up to 6 trend lines and assign process value from drop-down list. Trend line colours are fixed.

NOTE:

If all trend lines are disabled, the trend screen will not be displayed in the User Trends screen.

11.11 Archive settings

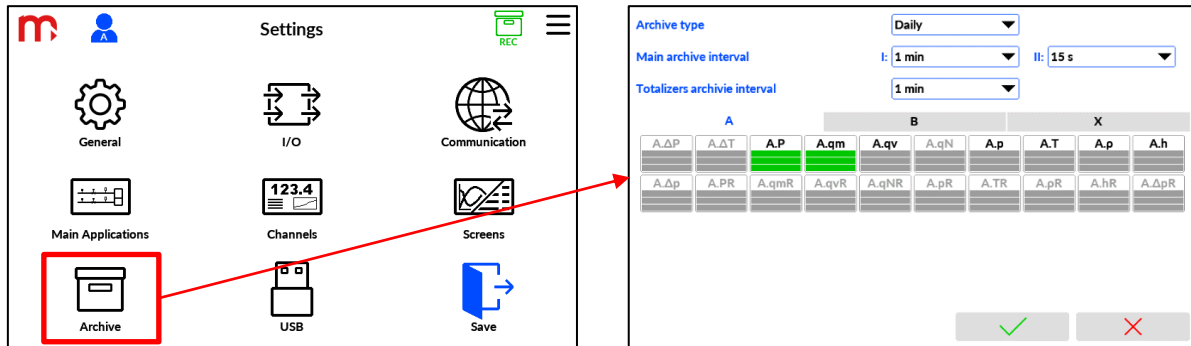

Archive type: Daily (Daily, Weekly, Monthly) ^[1]

Main archive: interval ^[2]

I: 2 s (1 s, 2 s, 5 s, 10 s, 15 s, 30 s, 1 min, 5 min, 10 min, 15 min, 30 min, 1 h, 2 h, 4 h, 12 h)^[2]

II: 2 s (1 s, 2 s, 5 s, 10 s, 15 s, 30 s, 1 min, 5 min, 10 min, 15 min, 30 min, 1 h, 2 h, 4 h, 12 h)^[2]

Totalizers archive interval: 1 min (1 min, 5 min, 10 min, 15 min, 30 min, 1 h, 2 h, 4 h, 12 h, 24h)^[3]

[1]: Archive files are created in Daily (a new archive files package created at midnight), Weekly (a new archive files package created at midnight from Sunday to Monday) or Monthly (a new archive files package created at midnight between the last day of the month and the first day of the following month).

[2]: For the Main archive there are two recording frequencies controlled by channel alarms: I and II.

[3]: For totalizers there is one recording frequency.

NOTE:

The frequency of recording to the archive should be properly selected for the measurement process. Recording too often results in the accumulation of a large number of data, which makes it difficult to analyse. On the other hand, too rare recording may result in the loss of rapid changes in measured processes.

At the bottom half of the screen there are tabs A, B and X with information which channels are declared for archiving. The selecting is set in [Channels](#).

Each rectangle contains three bars corresponding to archiving: the process value - the top bar, the first totalizer - middle bar and the second counter - bottom bar. Declared for archiving value is marked in green.

For disabled channels are shadowed description is gray.

11.12 USB screen, write and read settings file

Only a flash drive in FAT format can be connected to the device (according to the chapter [Write and read files via USB](#)). For the Administrator logged-in, it is possible to save and upload the settings to/from a USB flash drive. The settings file have to be prepared in PC computer using dedicated software. It is also possible copy settings from another device.

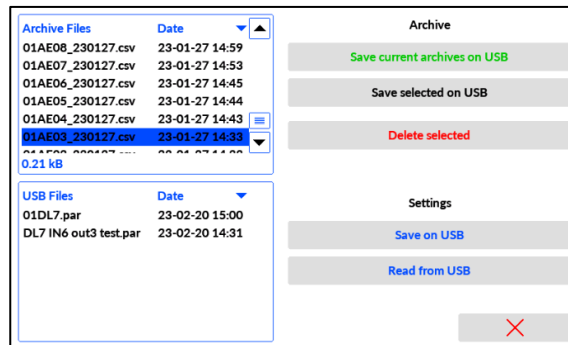

After uploading the new settings file from the external USB flash drive, the device will automatically restart with the new settings.

Note:

Removing the flash drive before completing the read/write procedure may damage the copied files.

It is recommended to make a copy of the settings file on a flash drive each time after updating the settings.

11.13 Restore Factory settings

Factory settings may be restored for Administrator logged-in in the Service tab in the General Settings window. The device will automatically restart with the factory settings in the language used previously. Archive files will not be deleted. The Administrator password will not be changed. The User's password will be reset to the default.

Note:

Before restoring the device to factory settings, it is recommended to save the settings to a USB flash drive.

11.14 BTL service button.

During startup of device BTL button is used in order to upload new firmware via USB. At normal work BTL button invoke printscreen function of current window.

12 EXTRA FEATURES

12.1 Computed channels

Auxiliary channels from application X and measuring channels from applications A and B may be configured to process computations according to entered mathematical formula. The formula may contain other channels results or constant values and perform selected mathematical operations: addition, subtraction, division, multiplication, raising to 2, 3 or any power and root. It is also possible to use totalizers results in the formula. The formula is entered as a text string and can be up to 200 characters long.

The formula can be entered when channel type is selected as *Computed* and by tapping the formula field.

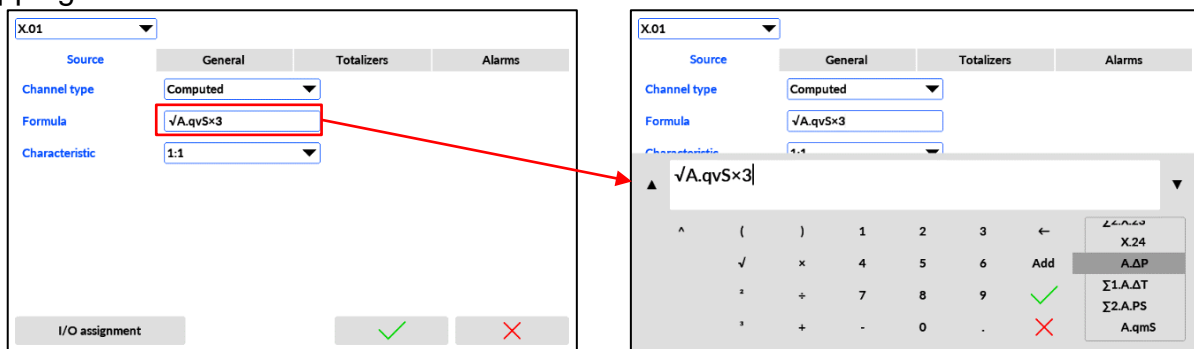

The device performs calculations according to the order in which the actions are performed (operations in parentheses, exponentiation, root, division, multiplication, addition, subtraction). Below there are examples explaining the idea of building the formulas in the device.

Example:

The use of process values or totalizers from different applications.

$$A.qm + B.qm \quad \text{sums up the mass flow rates from application A and B}$$

Example:

The use of totalizers in formulas require careful prediction of possible maximum values. The calculation result is a process value and has smaller maximum number then totalizers.

$$\Sigma 1.A.qm + \Sigma 1.B.qm \quad \text{sums up two totalizers}$$

Exmample:

The use alarm states to calculate data only when alarm is active

$$@1.A.qm \times A.qm \quad \text{copy value only when alarm 1 is active}$$

Example:

In the case of root, only the first number entered after the $\sqrt{\quad}$ sign is calculated. If the root is to be calculated from the value of several channels, the brackets have to be used.

$\sqrt{123}$	calculates the square root of constant value 123
$\sqrt{A.qv}$	calculates the square root of the flow rate A.qv
$\sqrt{Aq.v+10}$	calculates the square root of the flow rate A.qv and adds 10
$\sqrt{(A.qv+B.qv)}$	calculates the root of the sum of the two flowrates

Example:

By analogy, in the case of exponentiation (available the second or third power), only the first value entered before the exponent is taken into power calculation.

123^2	raises 123 to the power of 2
$A.P^2$	raises the process value A.P to the power of 2
$A.P+B.P^2$	raises the value of the B.P to the power of 2 and adds A.P
$(A.P+B.P)^2$	raises the sum of A.P and B.P to the power of 2

Example:

The device allows to raise a number to any power (^ symbol). In the case of an exponent that is not an integer, the basis must be positive.

123^4	raises 123 to the power of 4
$123^{(-4)}$	raises 123 to the power of -4
123^{4^3}	means $123^{4 \cdot 3}$
$123^{(4^3)}$	means $123^{4^3} = 123^{64}$
$A.T^{(1 \div 3)}$	raises to power $\frac{1}{3}$ channel value 1
$A.T^{(B.T)}$	raises process value A.T to the power of the process value B.T
$A.T+B.T^{(1 \div 3)}$	raises process value B.T to the power of $\frac{1}{3}$ and adds A.T
$(A.T+B.T)^{(1 \div 3)}$	raises sum of A.T and B.T to the power $\frac{1}{3}$

12.2 User characteristics

The user characteristic may be entered and applied to every channel except *Internal* channels calculated by the flow algorithm (like e.g. compensated power of steam). The characteristic may be entered in settings in the device from LCD touch panel or imported from .csv type file to FP40 Config software and uploaded to the device via USB memory flash drive with settings.

User characteristics are given in the form of pairs of points: Measured or read or calculated value and displayed value in the engineering units (y value). User may change name of characteristic, *Add point*, *Delete point* and *Edit value* points. User can add up to 100 points. A valid characteristic must contain at least two points. User can add up to 10 own characteristics.

Editing user characteristics is only possible if the channel characteristic is set to User. To edit User Characteristic, select the characteristic type as *User* in the channel setting window. To edit characteristic tab button *Edit* button below selected user characteristic.



New points may be added in any order (*Add Point*), they are automatically sorted against the measured value (x). To delete a point, the value have to be selected (clicked), and then *Delete Point* tapped. To edit a point, the value have to be selected (clicked), and then *Edit Value* tapped.

Two identical measured values x may not be entered. The data entered in this way will be treated as incorrect and prevent to save characteristic. Wrong values will be marked in red.

12.3 User Unit

The device has defined list of engineering units available by default for process values. In some cases, it may be required to add and define own units. To get in to unit edit window the button *User units* in tab *General* for *Channels* have to be tapped. Up to 30 user units may be added.

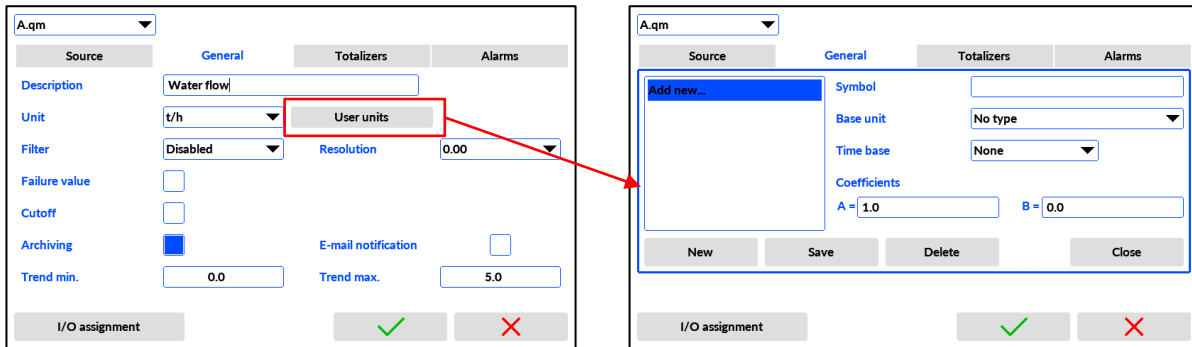

There are four parameters to be defined:

Symbol: [text] ^[1]

Base unit: No type (No type, kJ, °C, kg, m³, kg/m³, kJ/kg, kJ/kg*K, MPa[g, MPa]) ^[2]

Time base: None (None, Second, Minute, Hour) ^[3]

Coefficients: A= [value], B= [value] ^[4]

[1]: Unit abbreviation, maximum 11 characters long

[2]: Base unit is one of devices basic units to which the new unit refers to.

[3]: Time coefficient for the unit

[4]: Linear function coefficients ($y=A*x+B$) for new unit calculation from the base unit.

Below there are three examples of units, each has different usage in the measurement and is defined slightly in different way.

Example:

Length or level, e.g. level in tank of water measured in [cm]

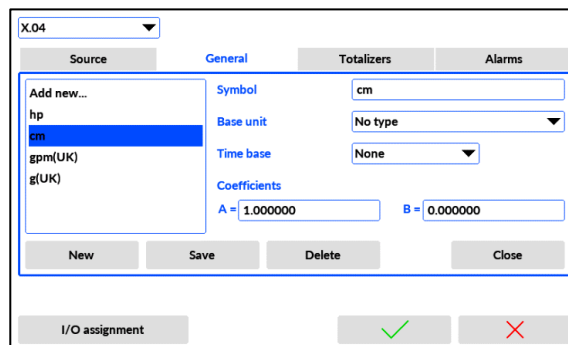

In this example the unit is only text information for the measured process value. Its abbreviation 'cm' is entered in *Symbol* field. *Base unit* is set to *No type* and *Time base* is set to *None*. *Coefficients A* and *B* are ignored.

Example:

Flow rate and flow, e.g. fuel supply for boiler house in UK gallons per minute unit.

In this example two units have to be defined, one for flow rate [gallons per minute, gpm(UK)], and another one for flow [gallons, g(UK)]. For flow rate *Base unit* is referred to m³ and *Time base* is set to *Minutes*. Coefficient A refers to ratio 1 g(UK) = 0,004546 m³. For flow *Time base* is set to *None*, and other parameters are the same. Unit [gpm(UK)] is used for process flow rate, and [g(UK)] for flow totalizer.

Example:

Steam power in not typical unit horse power (hp)

In this example power is calculated in steam application and is not directly measured but is result of calculations based on e.g. temperature, pressure and differential pressure measurements.

Horse Power abbreviation 'hp' is entered in *Symbol* field. For power, *Base unit* is referred to kJ and *Time base* is set to *Seconds*. (One kJ per second means one kW.) Coefficient A refers to ratio 1 kW = 0,746 hp.

12.4 User Medium

The flow computer can also support installations with other medium than water. For this purpose, the density and/or enthalpy tables of the medium shall be entered into the instrument as a function of temperature or pressure or both temperature and pressure. If user medium is used with orifice flow measurement it is also necessary to add viscosity value. The file with information about the medium should be prepared on a computer in a text editor or spreadsheet with a .csv extension.

12.5 In-Line Variable Area (ILVA) flowmeter calibration table

The use of In-Line Variable Area flowmeter requires entering calibration table. The calibration documentation is delivered together with every flowmeter.

POINT	CUSTOMER D.P. OUTPUT	D.P.	% D.P.	WATER MASS FLOW AT 20°C	WATER VOL. FLOW AT 20°C	% FLOW
	mA	mbar		kg/h	l/min	
1	4.020	0.620	0.12	116.13	1.94	1.21
2	4.549	17.093	3.43	254.74	4.25	2.66
3	4.963	29.988	6.02	444.95	7.43	4.65
4	5.385	43.135	8.66	616.34	10.29	6.44
5	5.902	59.225	11.89	892.29	14.90	9.32
6	7.480	108.342	21.75	1,757.33	29.34	18.36
7	8.838	150.630	30.24	2,647.96	44.21	27.66
8	10.338	197.331	39.61	3,568.01	59.57	37.27
9	11.740	240.980	48.37	4,471.55	74.66	46.71
10	13.079	282.678	56.74	5,213.83	87.05	54.46
11	14.455	325.523	65.34	6,103.40	101.91	63.75
12	16.040	374.886	75.25	7,113.07	118.76	74.30
13	17.542	421.641	84.64	8,046.73	134.35	84.05
14	19.700	488.820	98.12	9,387.31	156.74	98.05

The calibration table consists of the differential pressure and the mass flow values of the water equivalent. The calibration table is supplied in two versions, in metric and imperial units. Only metric tables ([mbar] / [kg/h]) can be used in the FP40, even when process values are set to imperial units.

The calibration table have to be entered by hand in the edit window or may be uploaded via USB port from memory stick as a .csv type file with dot as a decimal point and coma as a separator between numbers.

mbar,kg/h
0,0
0.620,116.13
17.093,254.74
29.988,444.95
43.135,616.34
59.225,892.29
108.342,1757.33
150.630,2647.96
197.331,3568.01
240.980,4471.55
282.678,5213.83
325.523,6103.40
374.886,7113.07
421.641,8046.73
488.820,9387.31
498.18,9608.89

The information and order inside the file is critical. The first line must specify the units. The last line is the maximum flow rate value for 498.18 mbar. This value is specified in documentation as the corrected water flow (typically in [l/min] and have to be recalculated to [kg/h] units in respect to water density).

<u>CALIBRATION CONDITIONS</u>	
Orientation	: Horizontal
Fluid	: WATER
Reference density at 20°C (68°F)	: 998.2 kg/m ³ (62.31 lb/ft ³)
Flow range	: 0 to 159.85 l/min (0 to 5.65 ft ³ /min)
Corrected water flow at 498.18 mbar**	: 159.86 l/min at 20°C (5.65 ft ³ /min at 68°F)
DP transmitter ranged 4-20 mA	: 0 to 498.18 mbar (200 inches water gauge)

Typical suggested by manufacturer differential pressure transmitter range is 0 to 498.18 mbar. (The FP40 device can accept dp transmitter in other range, as well.) If the pressure rises above the maximum value in the table, the flow rate value is extrapolated.

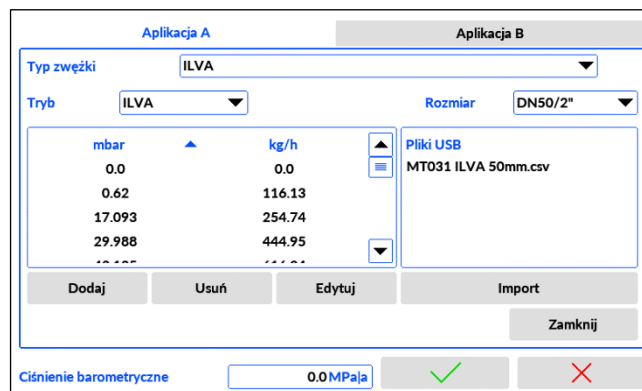

The entered calibration table may be used to calculate process values in steam or water applications.

13 MODBUS RTU / MODBUS TCP TRANSMISSION PROTOCOL

13.1 Basic information

Process values and counters are available as holding registers and input registers. It is only possible to read the registers.

13.1.1 Data types

uint/int 16bit	<i>Reg (Bit 15...0)</i>	
	HByte	LByte
	2.	1.

uint/int/flo at 32bit	<i>Reg_L (Bit 15...0)</i>		<i>Reg_H (Bit 31...16)</i>	
	HByte	LByte	HByte	LByte
	2.	1.	4.	3.

uint/int/flo at 32bit sw	<i>Reg_H (Bit 31...16)</i>		<i>Reg_L (Bit 15...0)</i>	
	HByte	LByte	HByte	LByte
	4.	3.	2.	1.

int/double 64bit	<i>Reg_L (Bit 15...0)</i>		<i>Reg_H (Bit 31...16)</i>		<i>Reg_L (Bit 47...32)</i>		<i>Reg_H (Bit 63...48)</i>	
	HByte	LByte	HByte	LByte	HByte	LByte	HByte	LByte
	2.	1.	4.	3.	6.	5.	8.	7.

13.2 Addresses of registers

Current results are available in an IEEE-754 standard floating point format for a 32-bit floating point. Float 32-bit values occupy two Modbus registers.

The counters are available in an IEEE-754 compliant floating point format for a 64-bit (double). Values in double 64bit format occupy 4 Modbus registers.

The register address table contains a map of Modbus addresses for all channels in the device. Regardless of the layout selected and the configured meters or additional channels, the address space of the device is fixed and according to the table below.

When reading data from the device, the correct data format, the starting address and the number of logs to be read should be indicated. For example, for the current supply temperature value in system A, i.e. the present value of the A.TS channel, the correct reading settings are:

Data format: *float 32 bit,*

Start address: *14,*

Size in registers: *2.*

		Current values	Totalizer 1	Totalizer 2
	Channel symbol	<i>(float 32bit)</i>	<i>(double 64bit)</i>	<i>(double 64bit)</i>
APPLICATION A	A.ΔP	0 .. 1	128 .. 131	384 .. 387
	A.ΔT	2 .. 3	132 .. 135	388 .. 391
	A.P / A.PS	4 .. 5	136 .. 139	392 .. 395
	A.qm / A.qmS	6 .. 7	140 .. 143	396 .. 399
	A.qv / A.qvS	8 .. 9	144 .. 147	400 .. 403
	A.qN / A.qNS	10 .. 11	148 .. 151	404 .. 407
	A.p / A.pS	12 .. 13	152 .. 155	408 .. 411
	A.T / A.TS	14 .. 15	156 .. 159	412 .. 415
	A.ρ / A.ρS	16 .. 17	160 .. 163	416 .. 419
	A.h / A.hS	18 .. 19	164 .. 167	420 .. 423
	A.Δp / A.ΔpS	20 .. 21	168 .. 171	424 .. 427
	A.PR	22 .. 23	172 .. 175	428 .. 431
	A.qmR	24 .. 25	176 .. 179	432 .. 435
	A.qvR	26 .. 27	180 .. 183	436 .. 439
	A.qNR	28 .. 29	184 .. 187	440 .. 443
	A.pR	30 .. 31	188 .. 191	444 .. 447
	A.TR	32 .. 33	192 .. 195	448 .. 451
	A.roR	34 .. 35	196 .. 199	452 .. 455
	A.hR	36 .. 37	200 .. 203	456 .. 459
	A. ΔpR	38 .. 39	204 .. 207	460 .. 463
APPLICATION B	B.ΔP	40 .. 41	208 .. 211	464 .. 467
	B.ΔT	42 .. 43	212 .. 215	468 .. 471
	B.P / B.PS	44 .. 45	216 .. 219	472 .. 475
	B.qm / B.qmS	46 .. 47	220 .. 223	476 .. 479
	B.qv / B.qvS	48 .. 49	224 .. 227	480 .. 483
	B.qN / B.qNS	50 .. 51	228 .. 231	484 .. 487
	B.p / B.pS	52 .. 53	232 .. 235	488 .. 491
	B.T / B.TS	54 .. 55	236 .. 239	492 .. 495
	B.ρ / B.ρS	56 .. 57	240 .. 243	496 .. 499
	B.h / B.hS	58 .. 59	244 .. 247	500 .. 503
	B.Δp / B.ΔpS	60 .. 61	248 .. 251	504 .. 507
	B.PR	62 .. 63	252 .. 255	508 .. 511
	B.qmR	64 .. 65	256 .. 259	512 .. 515
	B.qvR	66 .. 67	260 .. 263	516 .. 519
	B.qNR	68 .. 69	264 .. 267	520 .. 523
	B.pR	70 .. 71	268 .. 271	524 .. 527
	B.TR	72 .. 73	272 .. 275	528 .. 531
	B.roR	74 .. 75	276 .. 279	532 .. 535
	B.hR	76 .. 77	280 .. 283	536 .. 539
	B.ΔpR	78 .. 79	284 .. 287	540 .. 543

		Current values	Totalizer 1	Totalizer 2
	Channel symbol	<i>(float 32bit)</i>	<i>(double 64bit)</i>	<i>(double 64bit)</i>
APPLICATION X	X.01	80 .. 81	288 .. 291	544 .. 547
	X.02	82 .. 83	292 .. 295	548 .. 551
	X.03	84 .. 85	296 .. 299	552 .. 555
	X.04	86 .. 87	300 .. 303	556 .. 559
	X.05	88 .. 89	304 .. 307	560 .. 563
	X.06	90 .. 91	308 .. 311	564 .. 567
	X.07	92 .. 93	312 .. 315	568 .. 571
	X.08	94 .. 95	316 .. 319	572 .. 575
	X.09	96 .. 97	320 .. 323	576 .. 579
	X.10	98 .. 99	324 .. 327	580 .. 583
	X.11	100 .. 101	328 .. 331	584 .. 587
	X.12	102 .. 103	332 .. 335	588 .. 591
	X.13	104 .. 105	336 .. 339	592 .. 595
	X.14	106 .. 107	340 .. 343	596 .. 599
	X.15	108 .. 109	344 .. 347	600 .. 603
	X.16	110 .. 111	348 .. 351	604 .. 607

14 TECHNICAL SPECIFICATIONS

MEASUREMENT OF COMPENSATED FLOW AND THERMAL ENERGY	
Uncertainty of measurement of the flow of compensated steam, water, other liquid or technical gas	<2% (typically <0,5%)
Frequency of measurement and calculation of results	0,5 s
Front panel	
Display type	4" LCD TFT touch colour 800x480px
Display dimensions	86,4 mm x 52,5 mm
Keyboard	resistive touch panel
Additional signalling	3 colour LED
Port slot	Type-A socket, according to USB standard
Port USB	
Version	USB 2.0
Protection	IP54
Recording system	FAT16 (to a limited extent)
Record indication	LED on front panel
Port Ethernet	
Transmission protocol	Modbus TCP, ICMP (ping), DHCP server, http server
Interface	10BaseT Ethernet
Data buffer	300 B
Number of simultaneous open connections	4
Joint	RJ-45
LED Indicator Lights	2, Built into the socket RJ45
Modbus TCP Client	
Number of simultaneous open connections	Max 20
Number of values read	Max 30
Serial port RS485	
Signals output on the connector	A(+), B(-)
Load	32 receivers/transmitters
Maximum line length	1200 m
Maximum differential voltage A(+) – B(-)	-7 .. +12 V
Maximum total voltage A(+) to GND or B(-) to GND	-7 .. +12 V
Minimum transmitter output signal	1,5 V (at $R_0 = 54 \Omega$)
Minimum receiver sensitivity	200 mV / $R_{IN} = 12 k\Omega$
Minimum impedance of data transmission lines	54 Ω
Internal system of terminating resistors	Yes, activated by shorting the pins on the connector
Short-circuit/thermal protection	Yes/Yes
Transmission protocol	Modbus RTU
Baud	2.4, 4.8, 9.6, 19.2, 38.4, 57.6, 115.2 kbps
Parity check	Even, Odd, None
Frame	1b START, 8b data, 1b STOP
Isolation	no

Memory	
Memory Type	Flash
Memory Capacity	2 GB
Approximate recording time at 5s recording frequency for 16 measurement channels	approx. 2 years
Power	
Supply voltage	24 VDC (15 .. 30 VDC)
Maximum input power	14 VA / 14 W
Connecting wires	
Type	FP40: plug-in screw connectors
Wire cross-section	FP40: .max. wire cross-section 1,5 mm ²
Dimensions	
Enclosure type	For panel mounting, non-flammable plastic "Noryl"
Dimensions (W x H x D)	192 mm x 96 mm x 63,5 mm
Housing depth with connectors	ca. 72 mm
Panel cut-out dimensions (W x H)	186 ^{+1,1} mm x 92 ^{+0,9} mm
Maximum panel plate thickness	5 mm
Mass	ca. 0,7 kg
Environmental conditions	
Operating temperature	0 .. +40 °C
Relative humidity	0 .. 75% (no condensation)
Storage temperature	-20 .. +80 °C
Degree of protection from the side of the front panel	IP54
Rear plate protection	IP30
Pollution degree	PD 3
LVD (safety)	EN 61010-1
EMC	Directive 2014/30/UE: resistance in industrial environments according to EN 61326-1:2013 (Table 2) Conduction and radiation emission Class A according to EN 61326-1:2013
RoHS	Directive 2011/65/UE
Installation location	For internal use only
⁽²⁾ If additional protection against precipitation is provided (roofing), the device can be installed outside the building.	
Power Supply Module	
Analog output 4-20mA	
Output signal	4-20 mA (3.6 .. 22 mA)
Current loop supply	no (external supply required)
Maximum voltage between I+ and I-	28 VDC
Minimum supply current loop voltage	9 VDC (R _L = 0 Ω)
Loop resistance (R _L)	0 .. 500 Ω
Galvanic isolation to supply voltage	250 VAC; 1500 VAC for 1 minute
Accuracy	0,5%
Relay outputs	
Number of outputs	4
Outputs type	Solid state relays
Maximum voltage	60 V AC/DC
Maximum load current	0.1 A

I/O Modules	
IN6I(24V); IN6I – 0-20mA or 4-20mA input type module	
Number of inputs	6
How to connect the transducer	Passive transducer (loop powered) or active transducer
Measuring range	0–20 mA; 4–20 mA; (the actual range -22 .. 22 mA)
Resolution	0.001 mA
Measurement accuracy (T _a = +25 °C)	< ±0,1% measuring range (typically < ±0.05%)
Temperature drift	< ±0.02% /°C measuring range
Input resistance	12 Ω ±10%
Maximum input voltage	± 40 VDC
Input protection	Polymer fuse 50 mA
Transducers powered from device: module IN6I(24V) module IN6I	24 VDC ±15% / max 22 mA None
Galvanic separation from the other circuits	250 VAC; 1500 VAC for 1 minute
Galvanic separation between channels	None
IN6T – six-channel temperature input module	
Number of inputs	6
Sensor type	Resistance (Table below); 0 .. 4500 Ω Thermocouple (Table below); ±140 mV
Maximum input voltage	± 30 VDC
Galvanic separation from the other circuits	250 VAC; 1500 VAC for 1 minute
Galvanic separation between channels	None
Input resistance	>100 kΩ
Specifications for input type RTD	
Measuring range	-200 .. +850 °C for Pt100, Pt200, Pt500, Pt1000 -60 .. +150 °C for Ni100 -180 .. +200 °C for Cu100
Wire resistance compensation	set in the range -99.99 .. +99.99 Ω
Sensor connection type	2-wire; 3-wire; 4-wire
Sensor current	200 μA
Measuring range	0 .. 4500 Ω
Resolution	0.05 Ω
Wire resistance compensation in the 3-wire connection	Automatic
Wire resistance correction in the 2-wire, 3-wire, 4-wire connection	Constant within the range of -99.99 .. +99.99 Ω
Maximum resistance of the sensor wires	20 Ω
Specifications for input type TC	
Measuring range	-140 .. +140 mV
Resolution	0.01 mV
Cold junction compensation	Any other temperature measuring channel (in C/ F) or a constant value, Internal sensor measurement: accuracy ±2.5 C (value can be calibrated by the user), For thermocouple B – no compensation

IN6V – voltage type input module	
Number of inputs	6
Sensor type	0-10 V (2-10 V, 0-5 V, 1-5 V) Linear voltage source
Measuring range	-10 .. +10 VDC (or sub-range) (the actual range -11 .. +11 VDC)
Resolution	0.0001 V
Measuring range (T _a = +25 °C)	< ±0.1% measuring range (typically < ±0.05%)
Temperature drift	< ±0.02% /°C measuring range
Input resistance	>100 kΩ
Maximum input voltage	± 40 VDC
Galvanic separation from the other circuits	250 VAC; 1500 VAC for 1 minute
Galvanic separation between channels	None
IN6 – six-channel universal analog input module	
Number of inputs	6
Sensor type	Resistance (Table below); 0 .. 4500 Ω Thermocouple (Table below); ±100 mV 0–20mA; 4–20mA (supply loop module) ±10V / 0-10V (2-10V, 0-5V, 1-5V)
Maximum input voltage	± 30 VDC
Galvanic separation from the other circuits	250 VAC; 1500 VAC for 1 minute
Galvanic separation between channels	None
Specifications for input type RTD	
Sensor connection type	2-wire; 3-wire; 4-wire
Sensor current	200 μA
Measuring range	0 .. 4500 Ω
Resolution	0.05 Ω
Wire resistance compensation in the 3-wire connection	Automatic
Wire resistance correction in the 2-wire, 3-wire, 4-wire connection	Constant within the range of –99.99 .. +99.99 Ω
Maximum resistance of the sensor wires	20 Ω
Specifications for input type TC	
Measuring range	-140 .. +140 mV
Resolution	0.01 mV
Cold junction compensation	Any other temperature measuring channel (in C/ F) or a constant value, Internal sensor measurement: accuracy ±2.5 C (value can be calibrated by the user), For thermocouple B – no compensation
Specifications for input type 0-20mA, 4-20mA	
Measuring range	0–20 mA; 4–20 mA; (acceptable range -22 .. 22 mA)
Resolution	0.001 mA
Measurement accuracy (T _a = +25 °C)	< ±0.1% measuring range (typically < ±0.05%)
Temperature drift	< ±0.02% /°C measuring range
Input resistance	12 Ω ±10%
Input protection	Polymer fuse 50 mA
Specifications for input type ±10V / 0-10V	
Measuring range	-10 .. +10 VDC (or sub-range) (acceptable range -11 .. +11 VDC)
Resolution	0.0001 V
Measuring range (T _a = +25 °C)	< ±0.1% measuring range (typically < ±0.05%)
Temperature drift	< ±0.02% /°C measuring range
Input resistance	>100 kΩ

IN4SG – four channel strain gauge input module	
Number of analog inputs	4
Number of binary inputs (tare)	4
Sensore type	Strain gauge sensor, strain gauge (quarter-, half-, full-bridge configuration available)
Measuring range	-30 .. +30 mV
Resolution	0,0001 mV
Accuracy	< ±0,1% of 10 mV range (typically < ±0,05 %)
Temperature drift	< ±0,01% /°C of 10 mV range
Strain gauge bridge supply voltage	5 VDC
Minimum bridge resistance (4 inputs used)	250 Ω
Minimum bridge resistance (2 inputs used)	125 Ω
Minimum bridge resistance (1 inputs used)	62 Ω
Maximum input voltage	± 40 VDC
Galvanic separation from the other circuits	250 VAC; 1500 VAC for 1 minute
Galvanic separation between analog channels	none
Binary inputs (tare)	Voltage type activation; 24 VDC/5 mA (range 10-36 VDC)
Switching level	ca. 6 VDC
Maximum input voltage	± 40 VDC
Galvanic separation from the other circuits	250 VAC; 1500 VAC for 1 minute
Galvanic separation between binary channels	Yes (functional separation)
IN6D – binary inputs module	
Number of inputs	6
Sensor type:	State tracking Frequency measurement 0.1 .. 1000 Hz Counting pulses (freq. range 0 .. 100 Hz)
Resolution measurement of frequency	0.1 Hz
Measuring range (measurement of frequency)	< ±0.01% measuring range (typically < ±0.005%)
Temperature drift (measurement of frequency)	< ±0.002% /°C measuring range
Input resistance	1.2 kΩ ±10%
Input voltage operation (switching level)	0 .. 4 VDC / 5.5 .. 34 VDC (3.6 mA) ⁽²⁾ (according to PN-EN61131-2 characteristic)
Maximum input voltage	-0.3 VDC / +36 VDC
Contacts debounce filtering	off / 1 ms / 3 ms
Power supply source for external transducers	24 VDC ±15% / max 50 mA Protected by thermal fuse
Galvanic separation from the other circuits	250 VAC; 1500 VAC for 1 minute
Galvanic separation between channels	None
⁽²⁾ If required, other switching current level at 0.45mA, 1.55mA or 2.44mA can be selected with jumpers located on the module PCB.	
IN3D – binary inputs module	
Number of inputs	3
Sensor type:	State tracking Frequency measurement 0.1 .. 12 500 Hz Counting pulses (freq. range 0.. 100 Hz)
Resolution measurement of frequency	0.1 Hz
Measuring range (measurement of frequency)	< ±0.01% measuring range (typically < ±0.005%)
Maximum input voltage	±28 VDC
Galvanic separation between channels	None, common GND potential for all inputs
Galvanic separation from supply voltage	400 VAC (functional isolation)
Features	Status detection Pulse counting Frequency measurement
Measuring range	0,02 Hz do 12,5 kHz
Minimum pulse width	20 μs (low pass filter off)

	5 ms (low pass filter on)
Basic error (for $T_a = 20\text{ °C}$)	0,02%
Configuration: OC/contact ⁽¹⁾	
Opening state voltage	12 V
Short-circuit current	12 mA
On/off threshold	2,7 V / 2,4 V
⁽¹⁾ Default.	
Configuration: voltage input	
Input resistance	>10 k Ω
On/off threshold	2,7 V / 2,4 V
Opening state voltage	12 V
Configuration: Namur	
High impedance state	0,4 .. 1 mA
Low impedance state	2,2 .. 6,5 mA
2RS485(24V); 2RS485 – RS485 ports input module (Modbus RTU Master)	
Number of ports	2
Maximum number of process values read	25 (one or both ports in total)
Signals output on terminal block	A(+), B(-), 2x G (G - signal ground)
Maximum bus load	32 receivers / transmitters
Transmission protocol	Modbus RTU Master
Transmission rate	1.2, 2.4, 4.8, 9.6, 19.2, 38.4, 57.6, 115.2 kbps
Parity control	Even, Odd, None
Frame	1 start bit, 8 data bits, 1 stop bit
Galvanic separation	250 VAC; 1500 VAC for 1 minute
Maximum length of line	1200 m
Internal terminating resistor	Vcc-A(+)-B(-)-G: 390 Ω - 220 Ω - 390 Ω (activated by DIP-switches)
Maximum differential voltage A(+), B(-)	-9 V ... +14 V
Minimum output signal of transmitter	1.5 V (at $R_L = 54\ \Omega$)
Minimum sensitivity of receiver	200 mV / $R_{IN} = 12\ \text{k}\Omega$
Minimum impedance of data transmission line	54 Ω
Short-circuit/thermal protection	Yes/Yes
Additional power supply 24 VDC source	3 four pole terminal block (+ + - -)
2RS485(24V) module	24 VDC $\pm 15\%$ / max 200 mA
2RS485 module	None
1HRT – HART (4-20 mA) port module	
Transmission protocol	Rev 4, rev 5, rev 6, rev 7 Primary Master or Secondary Master
Functions	Supported 0, 1, 3, 6, 9 commands: Reading PV, SV, TV, FV and DVC variables Reading the Long Address (rev 5, rev 6, rev 7) Changing the Short Address Reading the unique identifier frame (test)
Maximum number of devices	15
Maximum number of variables read	25
Multidrop operating mode	Yes, up to 15 devices (multidrop)
Loop power supply	24 VDC (max 60 mA)
Analog reading of the 4-20mA line	No
Galvanic separation from the other circuits	250 VAC; 1500 VAC for 1 minute
Internal resistor	250 Ω , disabled by default ⁽³⁾
⁽³⁾ The resistor can be switched on/off in the data logger I/O settings menu. The resistor is automatically disconnected in the event of a power outage.	
OUT6RL – relay outputs module	
Number of outputs	6
Sensor type	Solid-state relays (SSR)
Maximum operating voltage/operating current	24 VAC / 0.5 A or 36 VDC / 0.5 A
The maximum voltage allowed	42 VAC or 60 VDC
Maximum peak current	1.5 A for 1 ms

Galvanic separation from the other circuits	250 VAC; 1500 VAC for 1 minute
Galvanic separation between channels	250 VAC; 1500 VAC for 1 minute
OUT3 – analogue outputs module	
Number of outputs (channels)	3
Specifications for current output	
Range (program selected)	4 - 20 mA 0 - 20 mA 0 - 24 mA
Output type	Active current source
Possibility of powering the current loop from an external voltage source	None
Resolution	12 bit / 0.006 mA
Accuracy ($R_L=350 \Omega / T_a = +25 \text{ }^\circ\text{C}$)	< $\pm 0.15\%$ (< $\pm 0.036 \text{ mA}$) full range of measurement (FSR)
Accuracy ($R_L=350 \Omega / T_a = -40 \dots +50 \text{ }^\circ\text{C}$)	< $\pm 0.3\%$ (< $\pm 0.072 \text{ mA}$) full range of measurement (FSR)
Load resistance R_L	0 Ω .. 500 Ω
Maximum output voltage (for $R_L = \infty \Omega$)	21.5 V
Specifications for voltage output	
Range (program selected)	0 - 5 VDC 0 - 10 VDC
Output type	DC voltage source
Resolution	12 bit (1.25 mV for 0 - 5 V) (2.5 mV for 0 - 10 V)
Accuracy $R_L=1 \text{ k}\Omega / C_L=200 \text{ pF} / T_a = +25 \text{ }^\circ\text{C}$	< $\pm 0.1\%$ full range of measurement (FSR) (Typically < $\pm 0.05\%$ FSR)
Accuracy $(R_L=1 \text{ k}\Omega / C_L=200 \text{ pF} / T_a = -40 \dots +50 \text{ }^\circ\text{C})$	< $\pm 0.3\%$ full range of measurement (FSR)
The minimum load resistance R_L	1 k Ω
The maximum load capacitance C_L	1 μF
Short-circuit protection	Yes
Specifications for current and voltage output	
Galvanic separation from other circuits	250 VAC; 1500 VAC for 1 minute
Galvanic separation between channels	250 VAC; 1500 VAC for 1 minute
PSBATT – back-up battery module⁽⁴⁾	
Input voltage 24 VDC IN	24 VDC / 2 .. 2.5 A
BATT1, BATT2 (capacity)	NiMH 2x9.6 V / 1000 .. 6000 mAh (Typically 4600 NiMH or 2000 mAh)
BATT1, BATT2 temperature sensor	2x NTC 10 k Ω
Charging time	ca. 12 h (full charging)
⁽⁴⁾ In the device, it is possible to install max 1 PSBATT module. From April 1, 2020, the PSBATT module is manufactured only in version 1.2. Version 1.2 of the module is not backward compatible. The Operating Manual contains information about the module's technical data in version 1.2. Technical details about the module in version 1.0 and in version 1.1 are available from the Manufacturer. Use only dedicated power supply.	

TABLE OF RTD SENSORS		
Sensor type	Measuring range	Accuracy
Pt100, Pt200, Pt500, Pt1000 (EN 60751+A2:1995)	-200 $^\circ\text{C}$.. +850 $^\circ\text{C}$ -328 $^\circ\text{F}$.. +1562 $^\circ\text{F}$	$\pm 0,5 \text{ }^\circ\text{C}$ (typ. $\pm 0,3 \text{ }^\circ\text{C}$) $\pm 0,9 \text{ }^\circ\text{F}$ (typ. $\pm 0,5 \text{ }^\circ\text{F}$)
Ni100, Ni120, Ni1000 (DIN43760 /08-1985)	-60 $^\circ\text{C}$.. +250 $^\circ\text{C}$ -76 $^\circ\text{F}$.. +482 $^\circ\text{F}$	$\pm 0,5 \text{ }^\circ\text{C}$ (typ. $\pm 0,3 \text{ }^\circ\text{C}$) $\pm 0,9 \text{ }^\circ\text{F}$ (typ. $\pm 0,5 \text{ }^\circ\text{F}$)
Cu50, Cu53, Cu100 (GOST6651-2009)	-180 $^\circ\text{C}$.. +200 $^\circ\text{C}$ -292 $^\circ\text{F}$.. +392 $^\circ\text{F}$	$\pm 0,5 \text{ }^\circ\text{C}$ (typ. $\pm 0,3 \text{ }^\circ\text{C}$) $\pm 0,9 \text{ }^\circ\text{F}$ (typ. $\pm 0,5 \text{ }^\circ\text{F}$)
KTY81 (NXP Rev05-25.04.2008)	-55 $^\circ\text{C}$.. +150 $^\circ\text{C}$ -67 $^\circ\text{F}$.. +302 $^\circ\text{F}$	$\pm 0,5 \text{ }^\circ\text{C}$ $\pm 0,9 \text{ }^\circ\text{F}$
KTY83 (NXP Rev06-4.04.2008)	-55 $^\circ\text{C}$.. +175 $^\circ\text{C}$ -67 $^\circ\text{F}$.. +347 $^\circ\text{F}$	$\pm 0,5 \text{ }^\circ\text{C}$ $\pm 0,9 \text{ }^\circ\text{F}$
KTY84 (NXP Rev06-8.05.2008)	-40 $^\circ\text{C}$.. +300 $^\circ\text{C}$ -40 $^\circ\text{F}$.. +572 $^\circ\text{F}$	$\pm 0,8 \text{ }^\circ\text{C}$ $\pm 1,5 \text{ }^\circ\text{F}$

15 ENTITY PLACING ON THE EU MARKET

Producer: METRONIC AKP Sp. J.
31-426 Krakow, ul. Zmujdzka 3
Tel.: (+48) 12 312 16 80
www.metronic.pl

Sales: